

# Upgrade Kit Assembly instruction

## General advice:

This is a temporarily version of the assembly instructions.

For the newest version of the assembly instruction visit:

<https://ifactory3d.com/support/>

To include the upgrade kit into your Printer you need to Print a few parts. The STL files and the new Firmware you find here:

<https://ifactory3d.com/downloads/>

After you have built up the upgrade kit you need do install a new firmware. You find the firmware and a manual for the firmware with the link above.

For the assembly of many components of the IFactory One, so-called T-nuts are used. The T-nuts need to be pushed into the profiles groove. This only works if the T-nut is in the correct position, as shown in the Picture below.

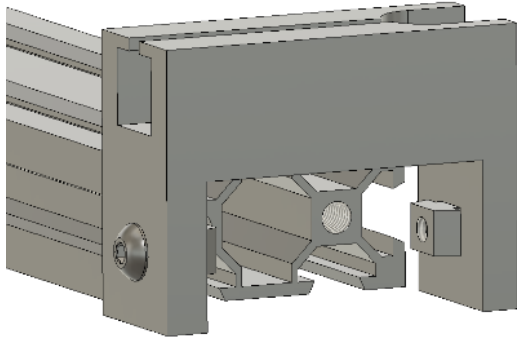

Once the T-nut is in the groove and the component is in place, the screw can be tightened. To create the desired clamping, the T-nut must be turned 90° as shown in the Picture.

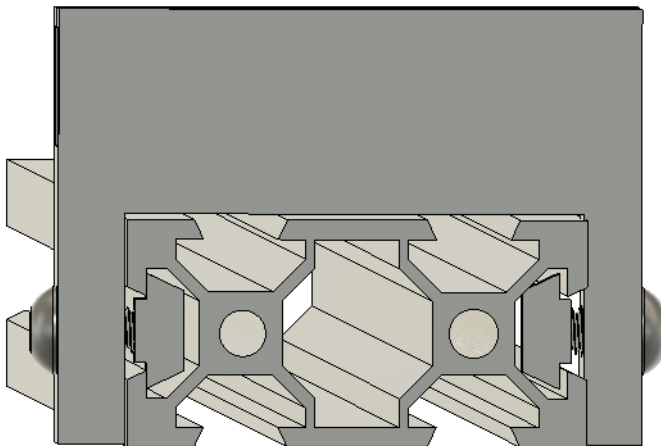

It may happen that the T-nut does not turn in the groove when the screw gets tightened. If this happens, you have to turn the screw back a little (do not turn the screw all the way out because then you will lose the nut!) and then tighten it again until the T-nut produces the desired clamping.

In general, screws in plastic components should not be tightened too much, otherwise they can break (as soon as you hear noises, do not continue turning).

## Part list



Hotend



Heatbreak

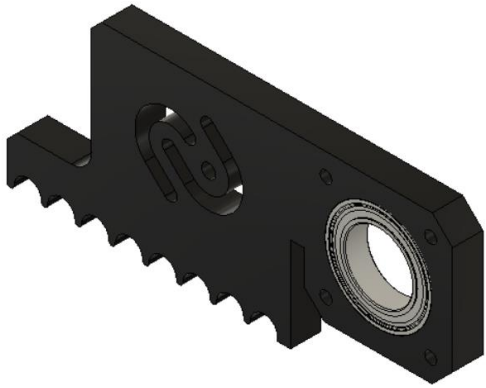

Bearing holder LB (LB, Left Back)

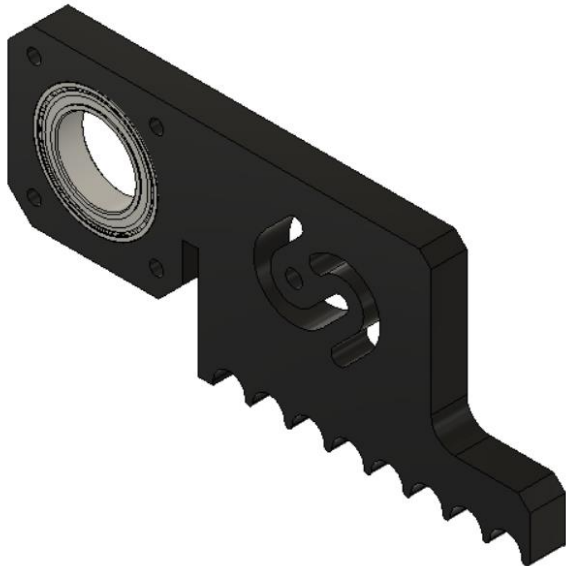

Bearing holder LF (LF, Left Front)

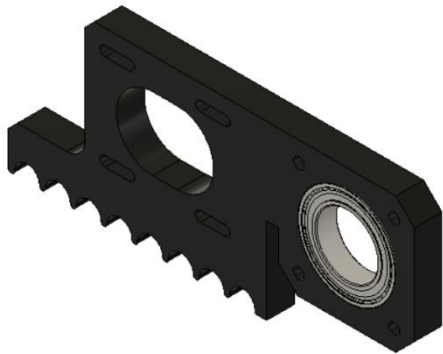

Bearing holder Z1 (right front)

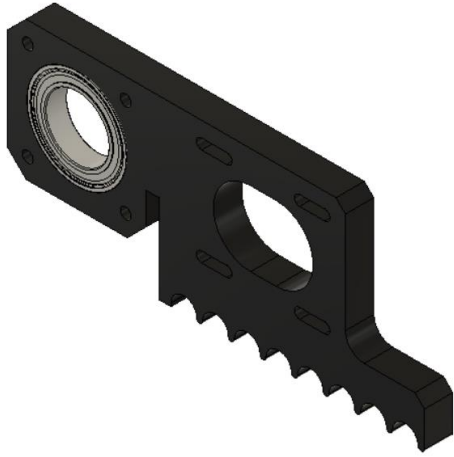

Bearing holder Z2 (right back)



X-motor bracket

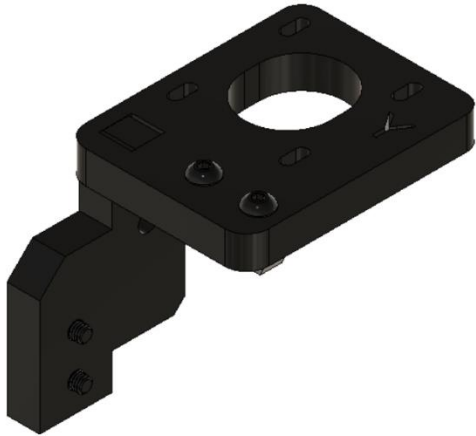

Y-motor bracket

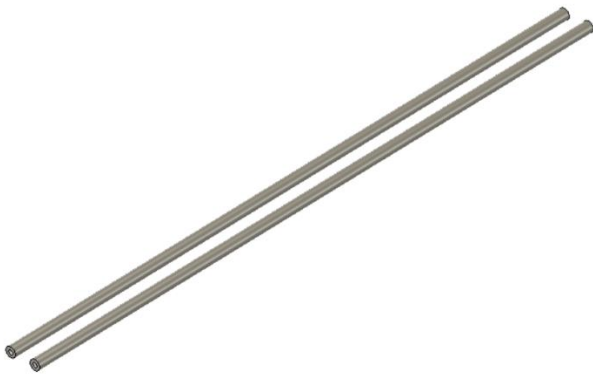

8mm rod

## Step 1: Disassembly of the extruder:

To mount the new extruder, you have to remove the old extruder first. Remove the filament out of the printer and dismantle the extruder.

Unscrew the circled screws in the picture below and detach the top cover of the extruder.

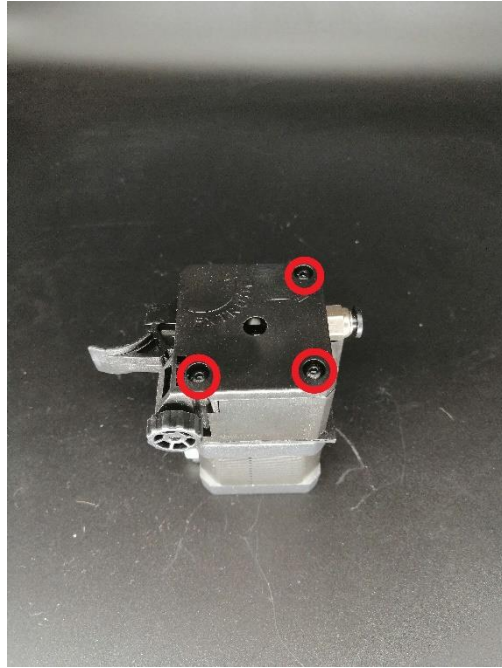

Now pull out all marked parts.

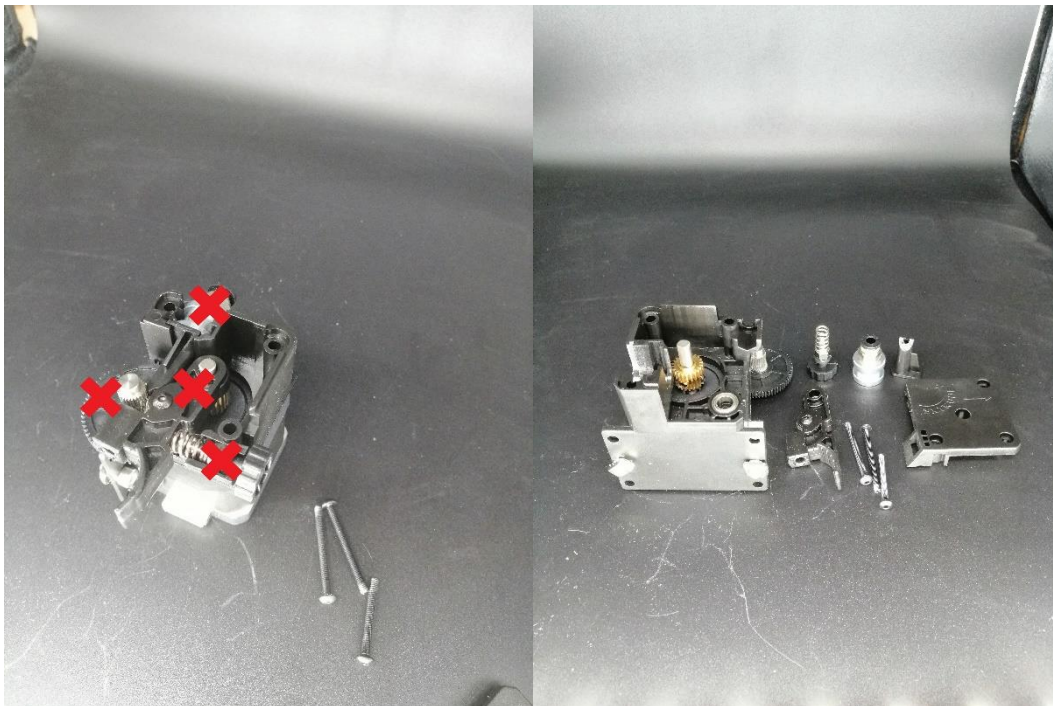

Unscrew the circled screws and detach the middle cover.



Unscrew the screw in the gear and remove it.





## Step 2: Disassembly of the printhead:

Remove the two screws of the part cooling fan to remove it.

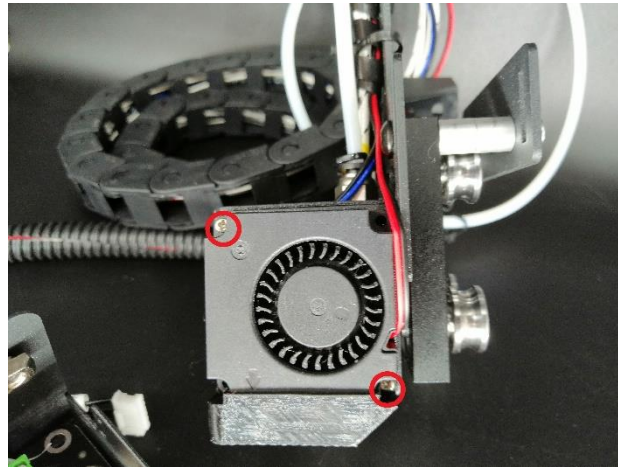

After this, remove the metal housing by unscrewing the circled screws and dismantle the cold end fan.

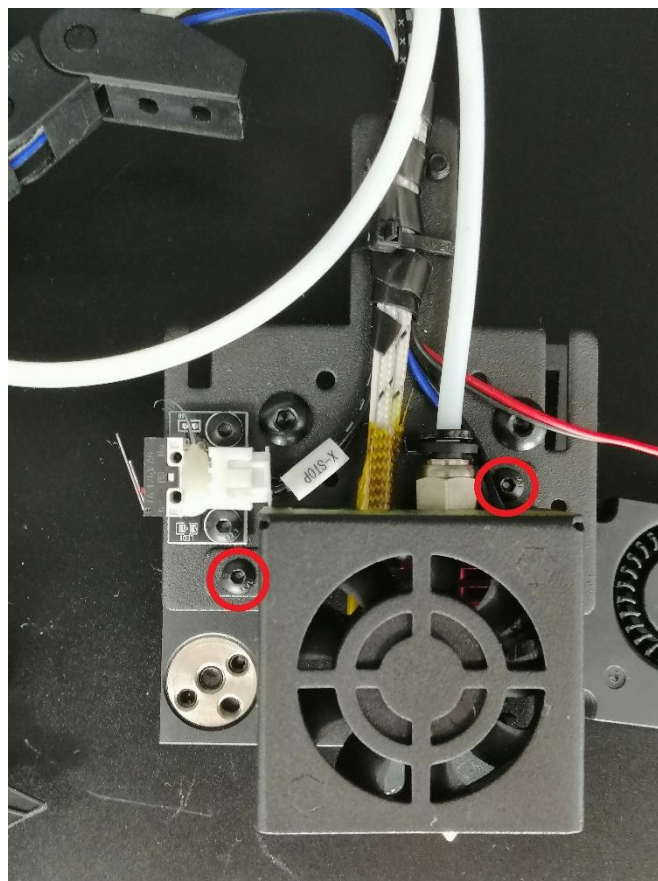

Dismantle the X endstop.

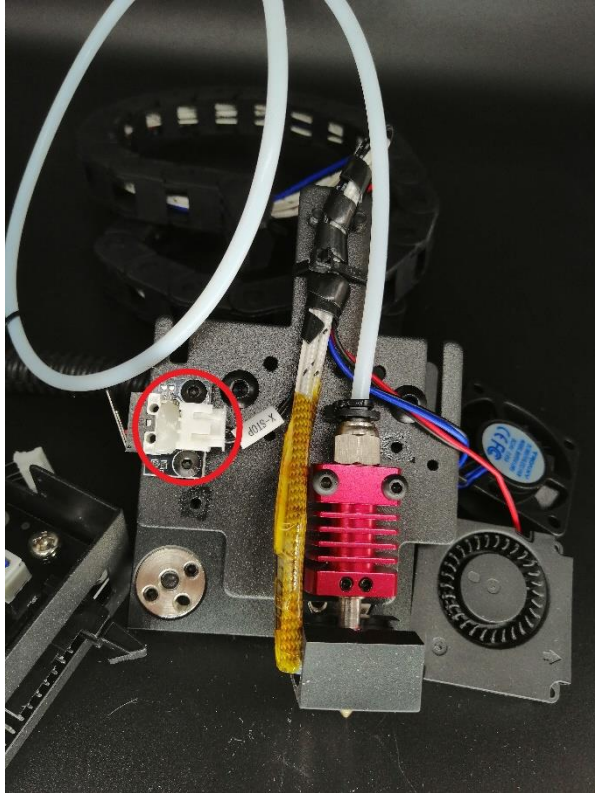

Remove the silicone protector from the Hotend if you have one. Also, you have to release the grub screw from the heating cartridge and temperature sensor and remove them from the heat block. If the cartridge is stuck quickly heat up the Hotend, carefully remove the cartridge and **shut the printer off as soon as possible!**

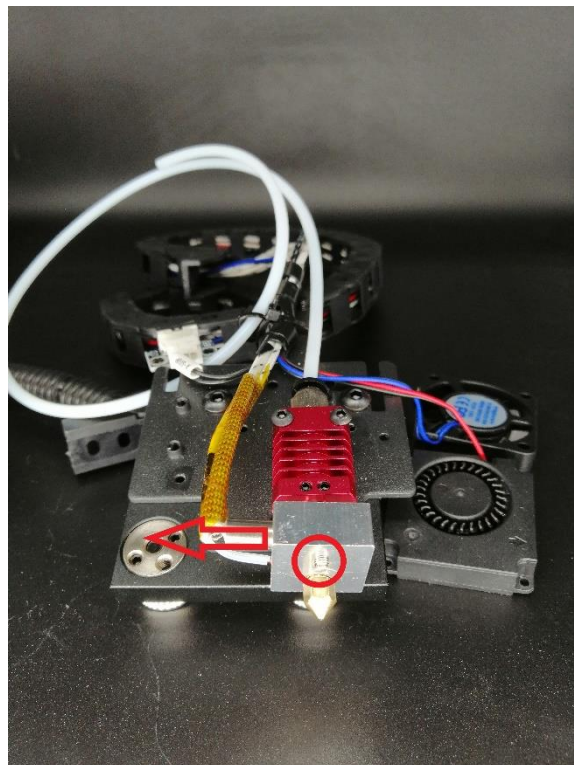

Dismantle the Hotend by removing the circled screws.

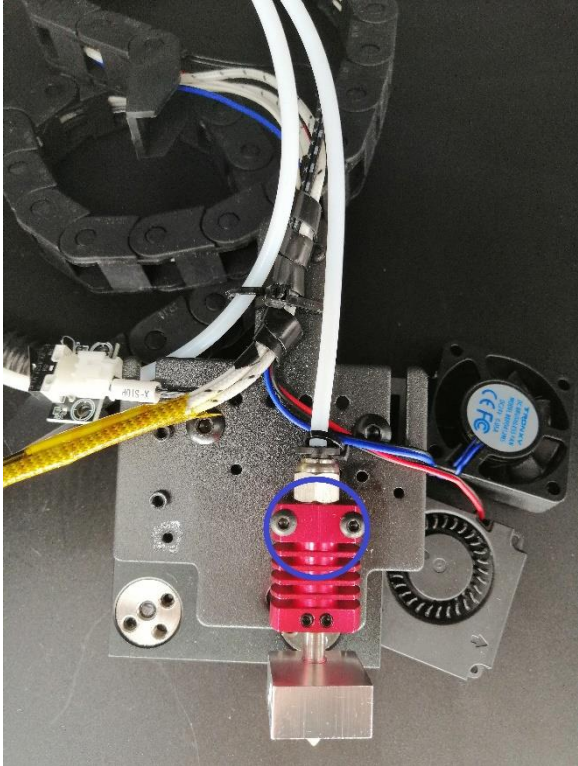

The printhead plate should look like this now.

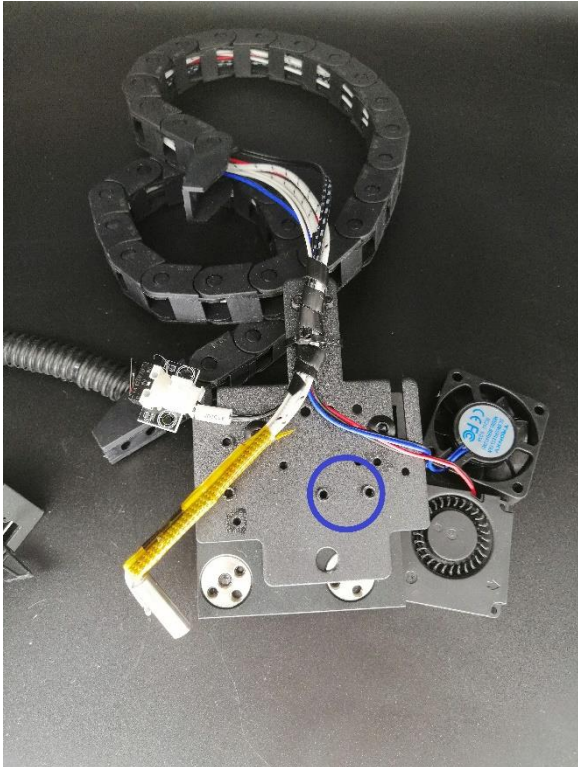

In the first versions of the iFactory One are brass spacers in the circled point, which you have to remove. If your printhead plate looks like in the picture above, you can go to the next step.

## Step 3: Assembly of the new printhead

Use some pliers to press in the M3-nuts into the printed plate.

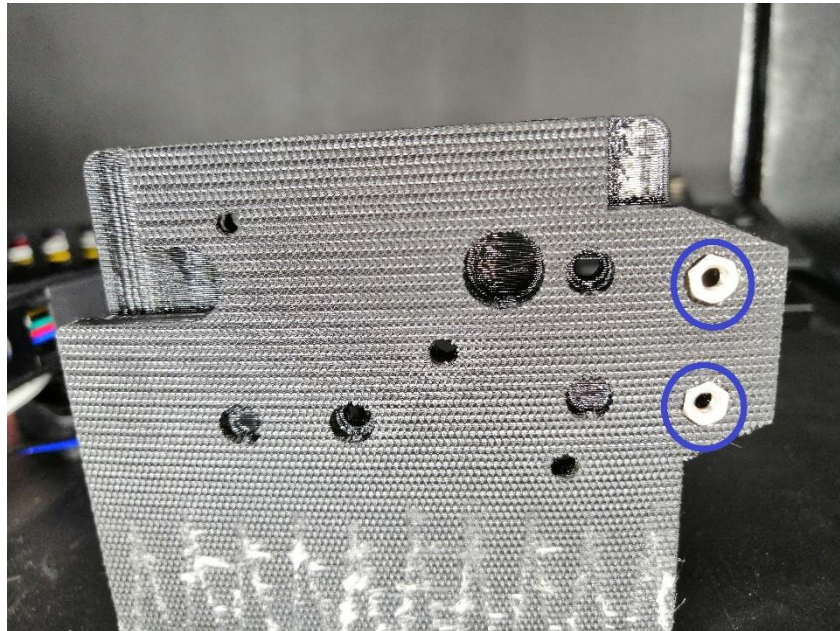

After this you can mount the plate to the printer. On the newer version you must use the screw on the upper left as well. The top right Screw (M3x12) needs to be mounted with a nut. All other screws are the included M3x8 screws.

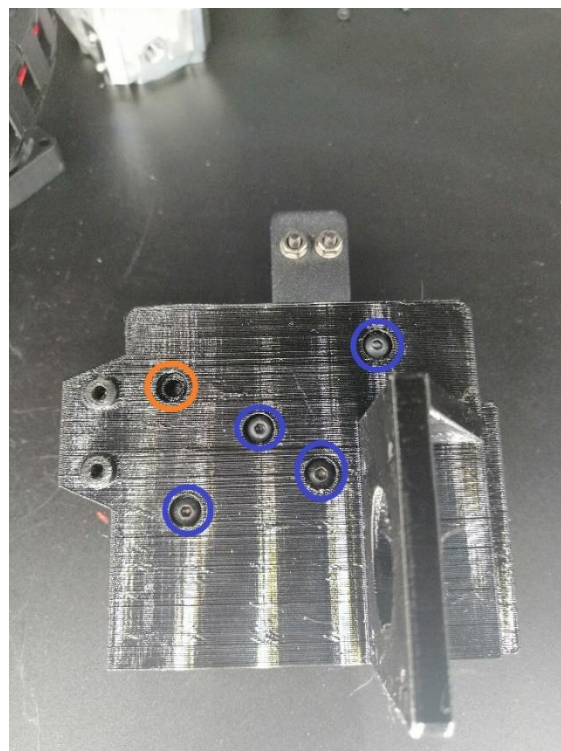

Insert the PTFE tube inside the not threaded part of the new Heatbreak.



Screw this side of the Heatbreak into the new extruder.

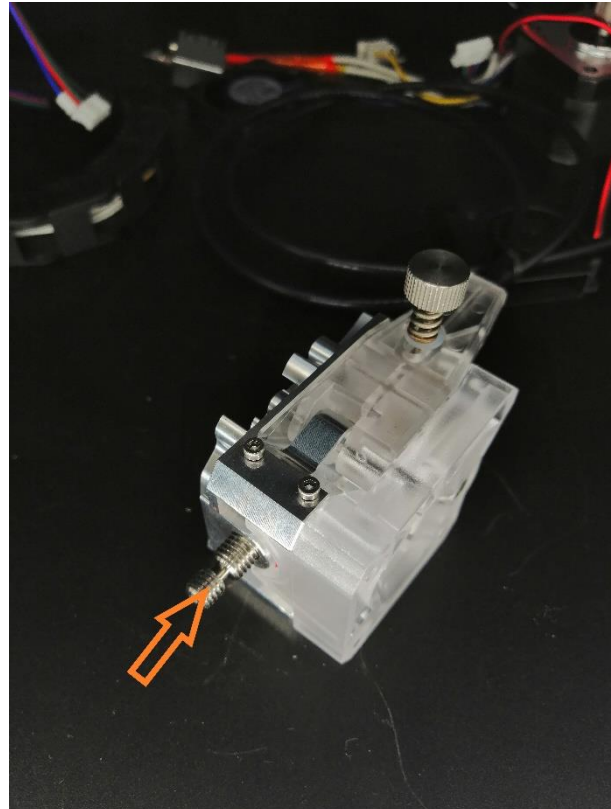

Release the circled screws and push in the heating cartridge from the top side into the Heatblock. Tighten the screws afterwards.



Mount the temperature sensor as shown in the picture below.

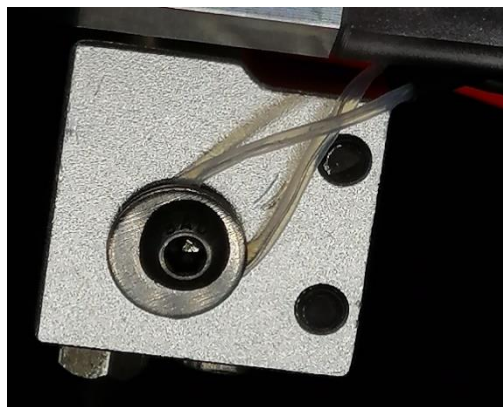

Now you can mount the new extruder with the Heatbreak to the hot end. Be careful that the position of the hot end and extruder are as shown in the picture below.

If the positions are good, you can tighten the nozzle to fix all positions. Before you start a print heat up the hot end and tighten the nozzle again.

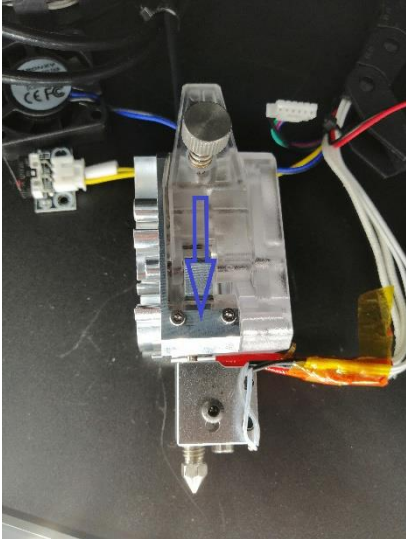

Dismantle the two circled screws.



Pull out the plastic transport protection with the gear.



Use the gear to mount it on the stepper motor from Step 1. The gear should have about 5mm space on every side. The side with the screw should be on the top.





Place the motor and the extruder as shown in the picture below on the printed plate.

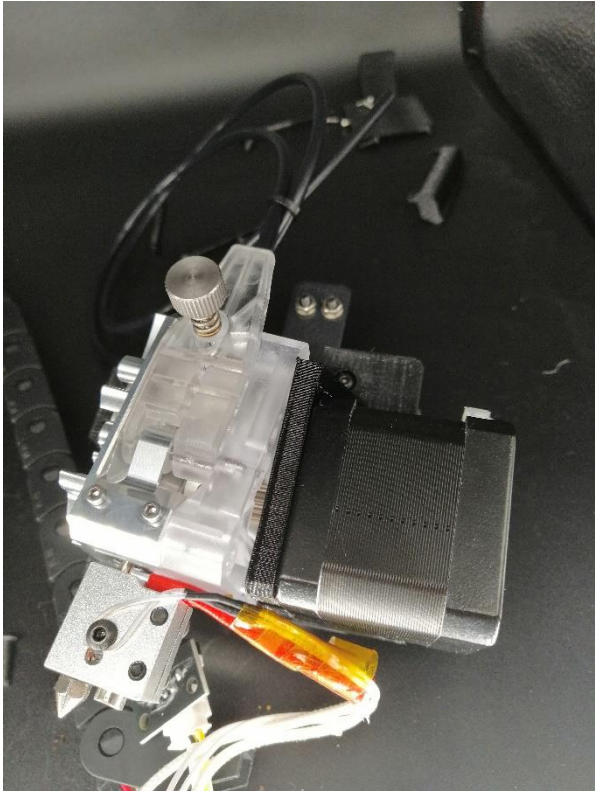

Screw in two M3x40 screws from the left side of the extruder as indicated in the picture.



Now you can mount the cooling fan (blue cable) to the cooling fins of the extruder. Use one M3x50 and one M3x12 screw.

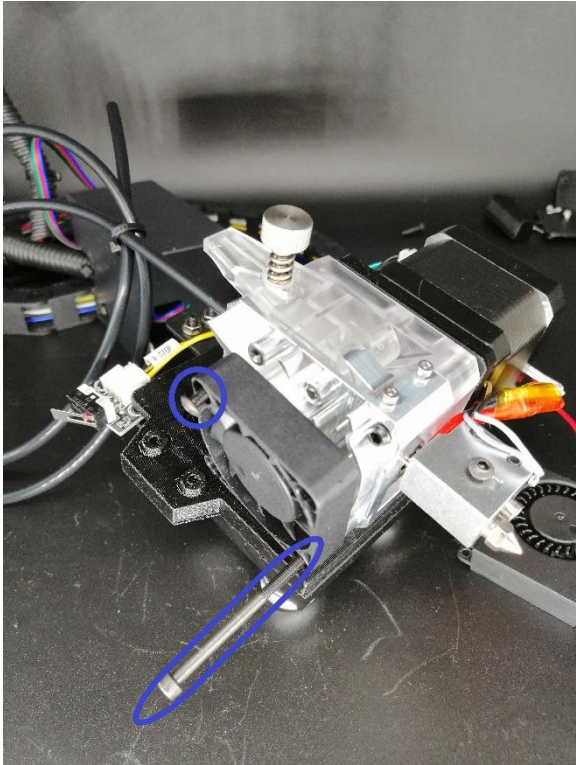

Assemble the part cooling fan back together with the two printed parts using the M2 x 6mm screws from the package.

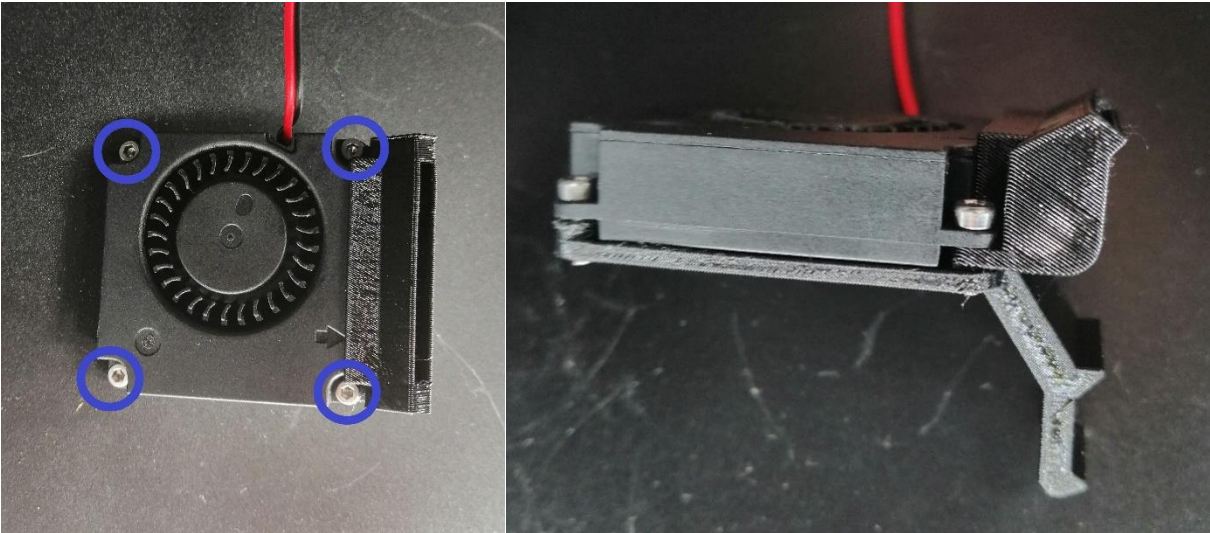

Use two M2 x 6mm screws to screw the part cooling fan to the Direct-Drive Extruder.

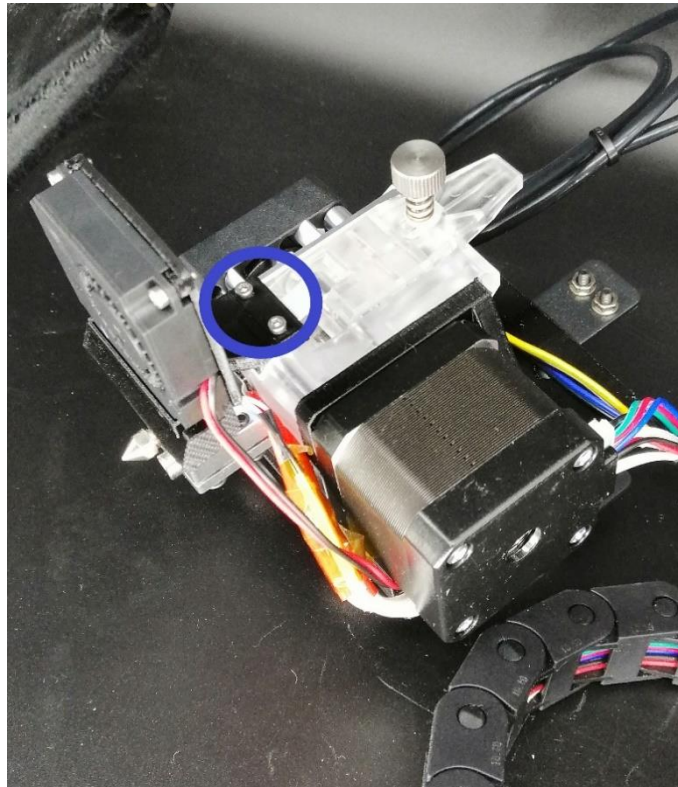

Now mount the X-Stop on the place as shown in the picture. Use M3x12 screws.

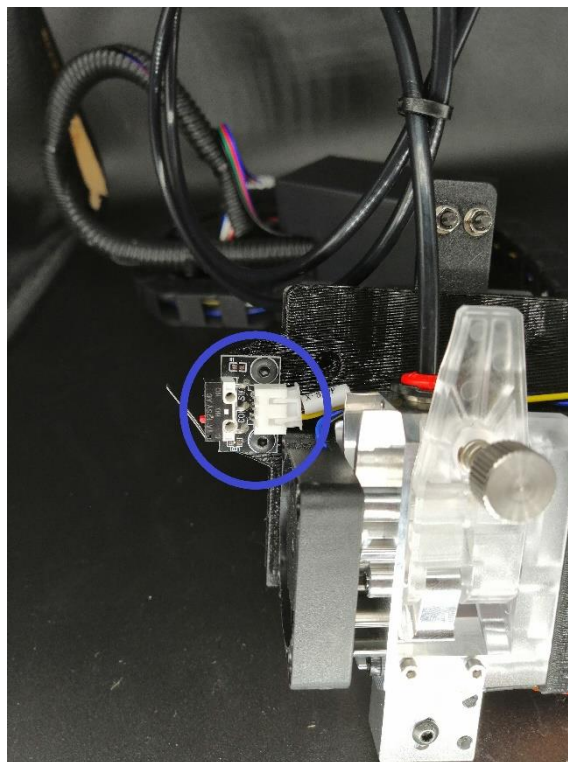

Plug in the included motor cable into the extruder and the electronic board. You can guide the cable through the drag chain or fasten it with zip ties to it.

If you want to pull the motor cable through the drag chain, the plug must first be removed. To do this, press down the silver lever in the plug and pull out the cable.

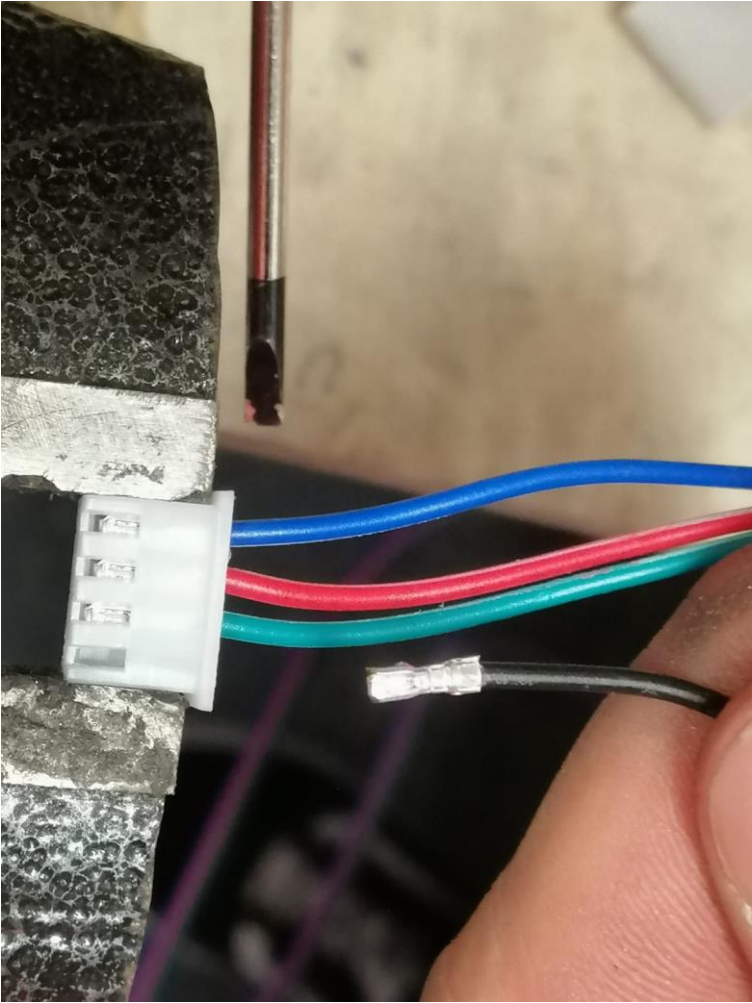
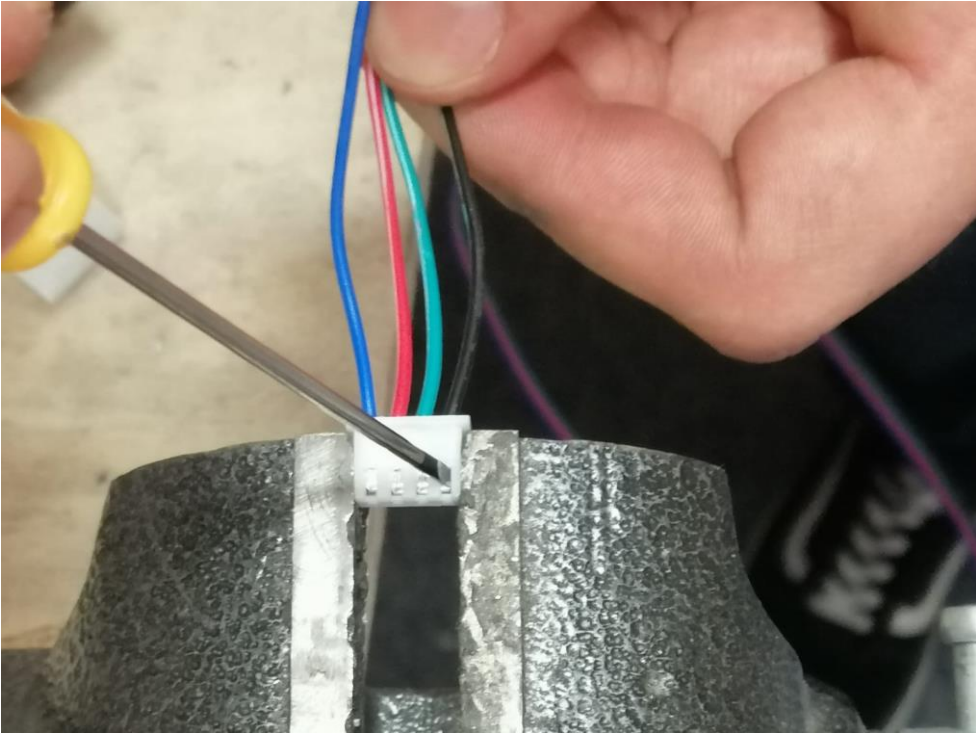

# Step 4: Dismantle of the X and Y motors

To dismantle the X and Y motors the belts need to be untightened. Therefore, cut the cable ties, which connect the belts with the printhead platform.

Next you can loosen the M4 screws in the motor plates and remove the motors from the top 20x20 profile.



Afterwards the motors need to be removed from their brackets. Unscrew all screws in the brackets and lay them to the side.



Mount the new motor brackets to the motors with the provided M3x12 screws.

Take care that the screws are placed at the bottom of the long hole and do not tighten the screws. The motors need to be pushed along the long hole in the next step. Also make sure that the motor connection is on the inside (opposite the bar).

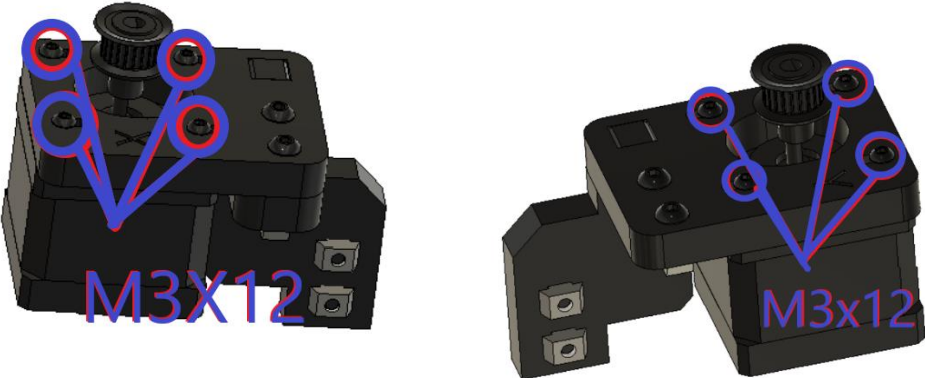

## Step 5: Mount the X and Y motors

The motors are mounted in the same position as bevor. Therefore slide the brackets into the top 20x20 profile and tighten all M4 Screws.

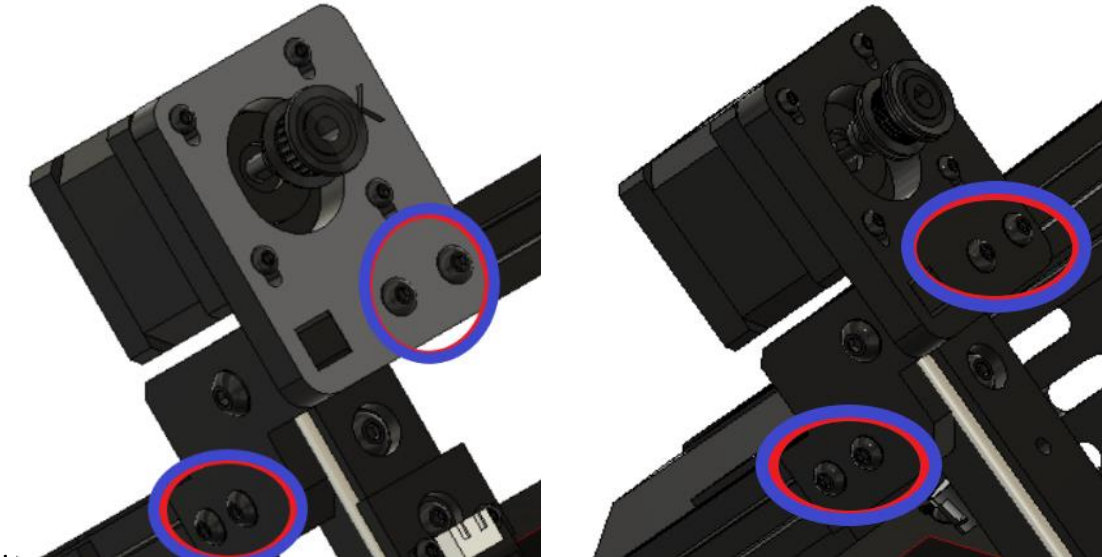

If you have a M5 thread cutter you can cut a thread into the top 20x20 extrusion and screw in M5x25 screws.

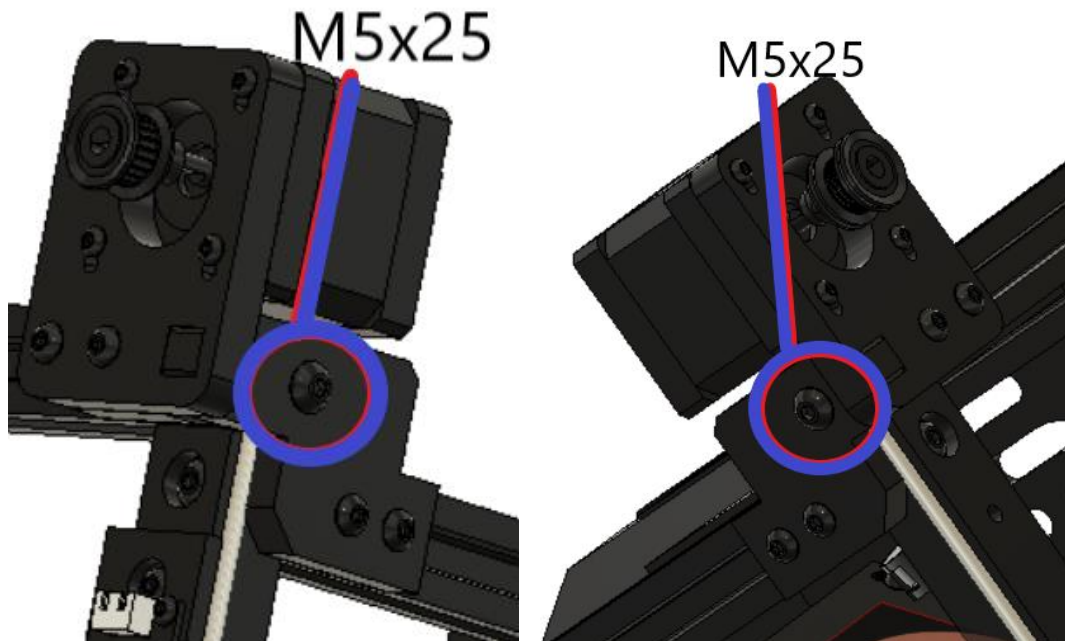

## Step 6: Tighten the X and Y belts

The next step is best done from the back of the printer. Place the gt2 belt over the Y-stepper motor pulley and then along all the other pulleys on the back as shown in the picture to build a core XY motion system. Tension (not too much, just secure that the belt does not sag) the belt to the printhead with a cable tie. This is best done from the back of the printer as well.

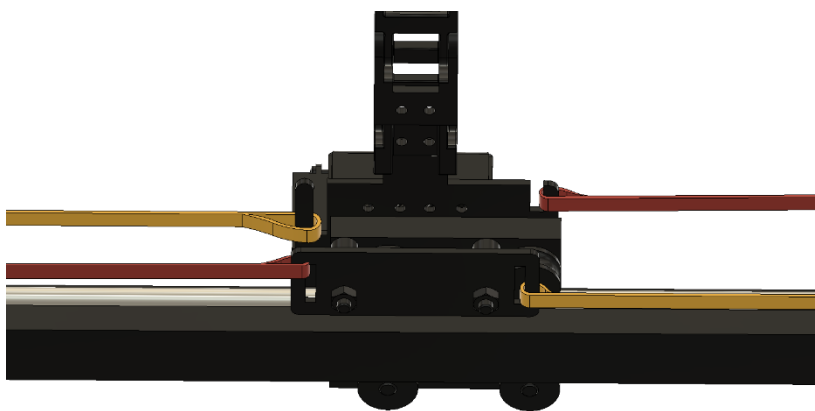

The other gt2 belt runs around the geared belt pulley of the X stepper motor and then along all the other rollers on the rear side as shown in the illustration. Tension the belt and mount it to the printhead using a cable tie.



Now push the motors to the top end of the long holes and secure it there (fasten the M3x12 screws).



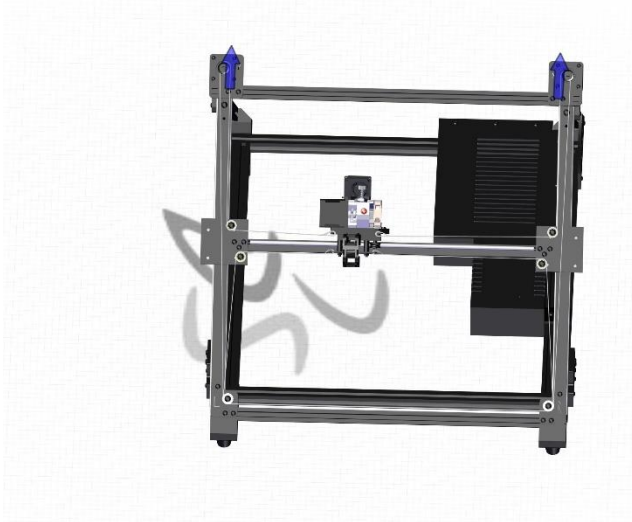

## Step 7: Dismantle the Belt group

To dismantle the belt group, the 8mm rod needs to be removed. Afterwards loosen the M4 screws (three at the bottom) of the two front belt tightening sliders and push it backwards until the belt is without tension.

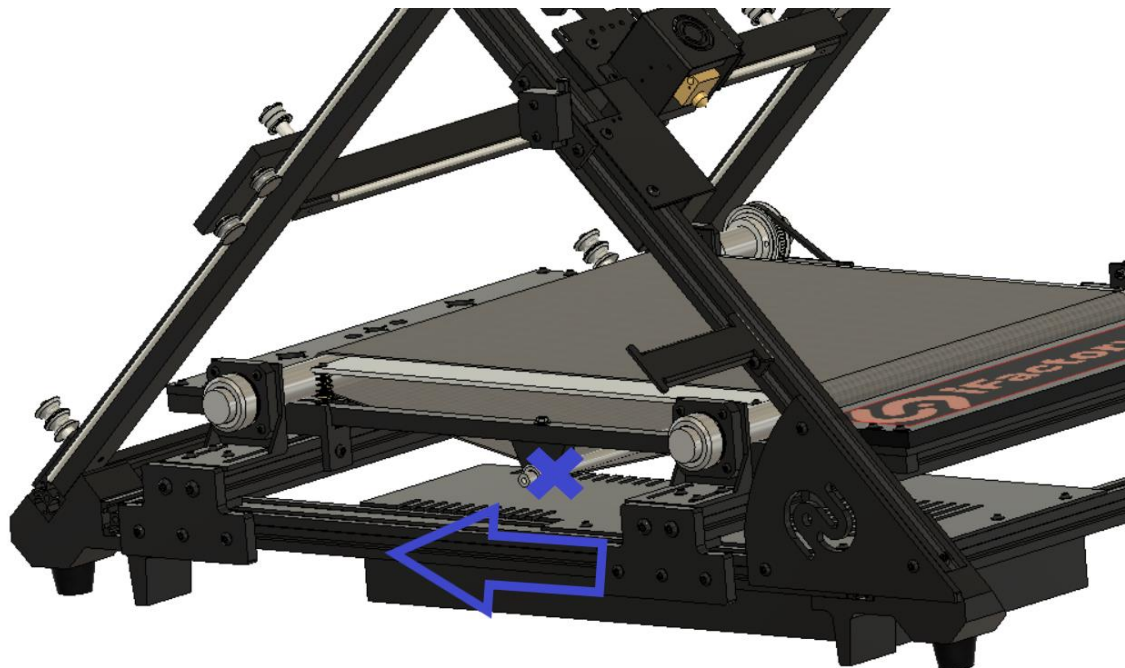

Dismantle the Z-motor from the 20x40 profiles as well as from their metal brackets and lay them to the side.

As soon as the belt is tensionless, unscrew the M5x25 screws with connects the belt tightening sliders and the 20x40 profile.

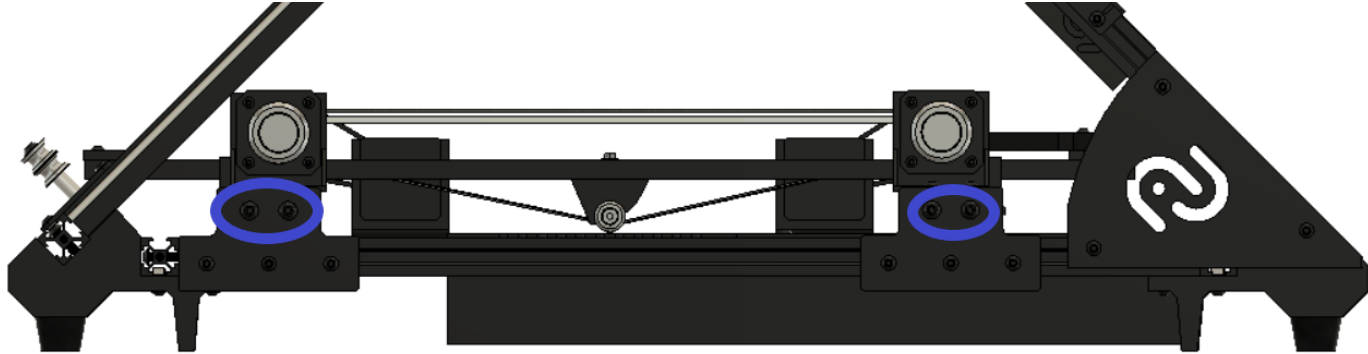

Lift out the Belt group at the 20x40 profiles.

## Step 8: Changing the belt group.

Dismantle the left collars from the 20mm shafts in the front and back.

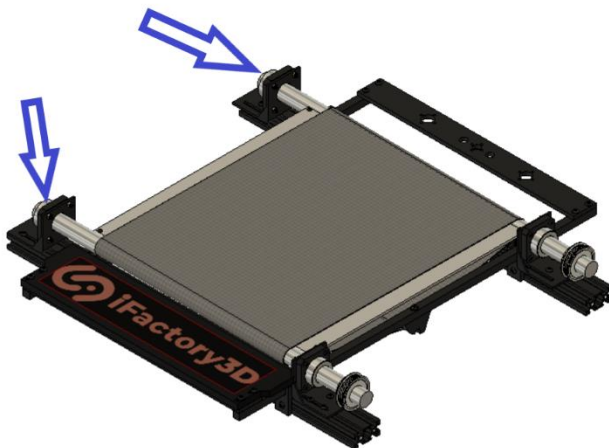

Now pull out the 20mm shafts.

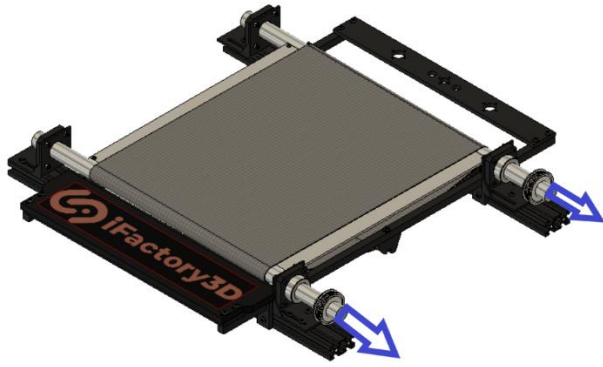

Dismantle the bearing brackets and belt tightener.

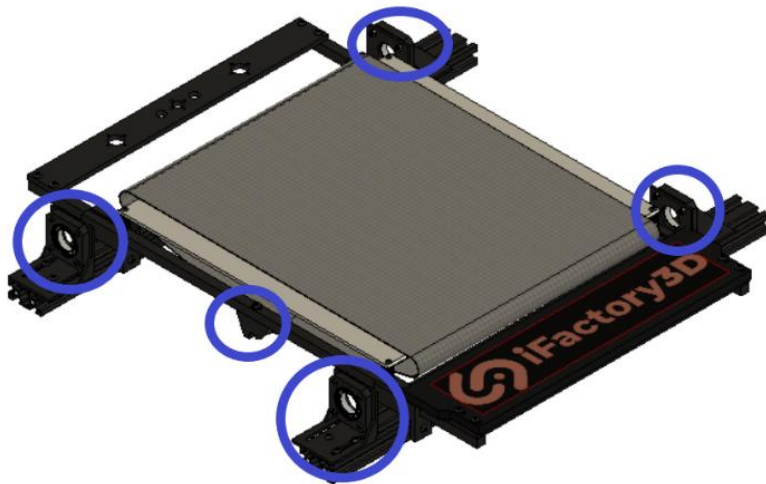

# Step 9: Mount the new bearing brackets.

Demount the bearing from the metal brackets. There are two brackets with an extra hole on the right side and two brackets with an extra hole on the left side.

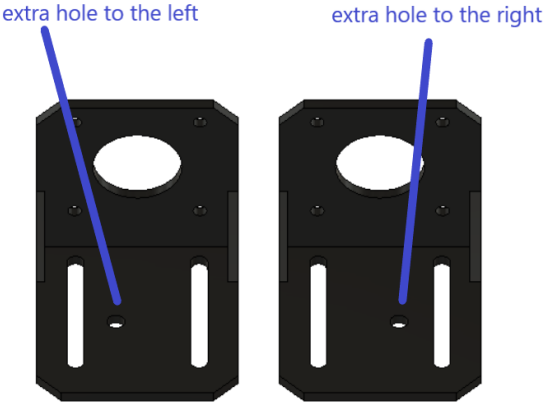

The new bearing brackets have a labelling: Z1, Z2, LB and LF.

Mount the new bearing brackets LB and Z1 to a metal bracket with an extra hole on the left site.

Mount the new bearing brackets LF and Z2 to a metal bracket with an extra hole on the right site.

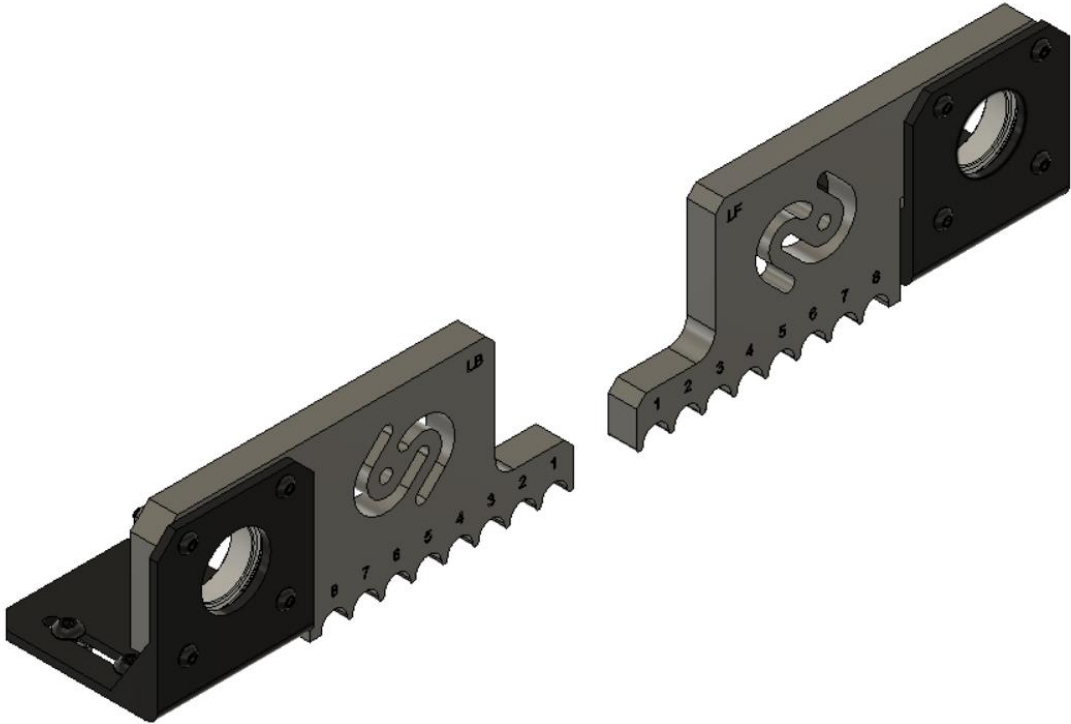

Mount the z-motors to the Z1 and Z2 bearing bracket as indicated in the pictures below.

Mount the new gears to the Z motors.

Take care of the screw placement and do not tighten them.

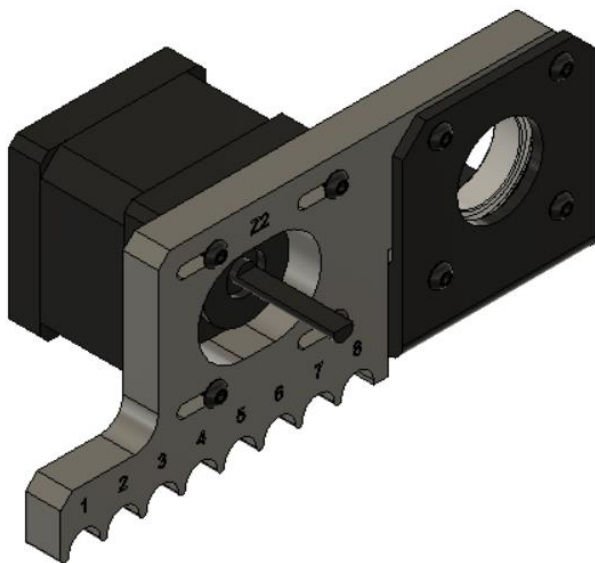
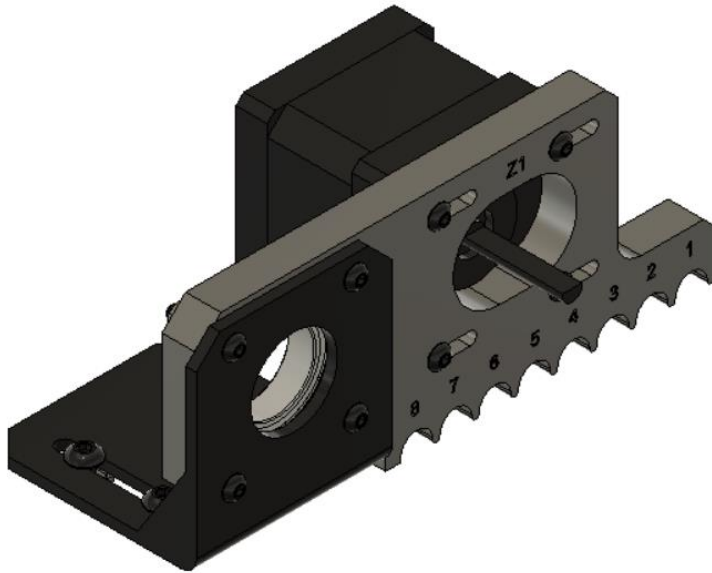

## Step 10: Mount the brackets to the belt group.

Mount the brackets to the 20x40 profiles of the belt group as shown in the picture.

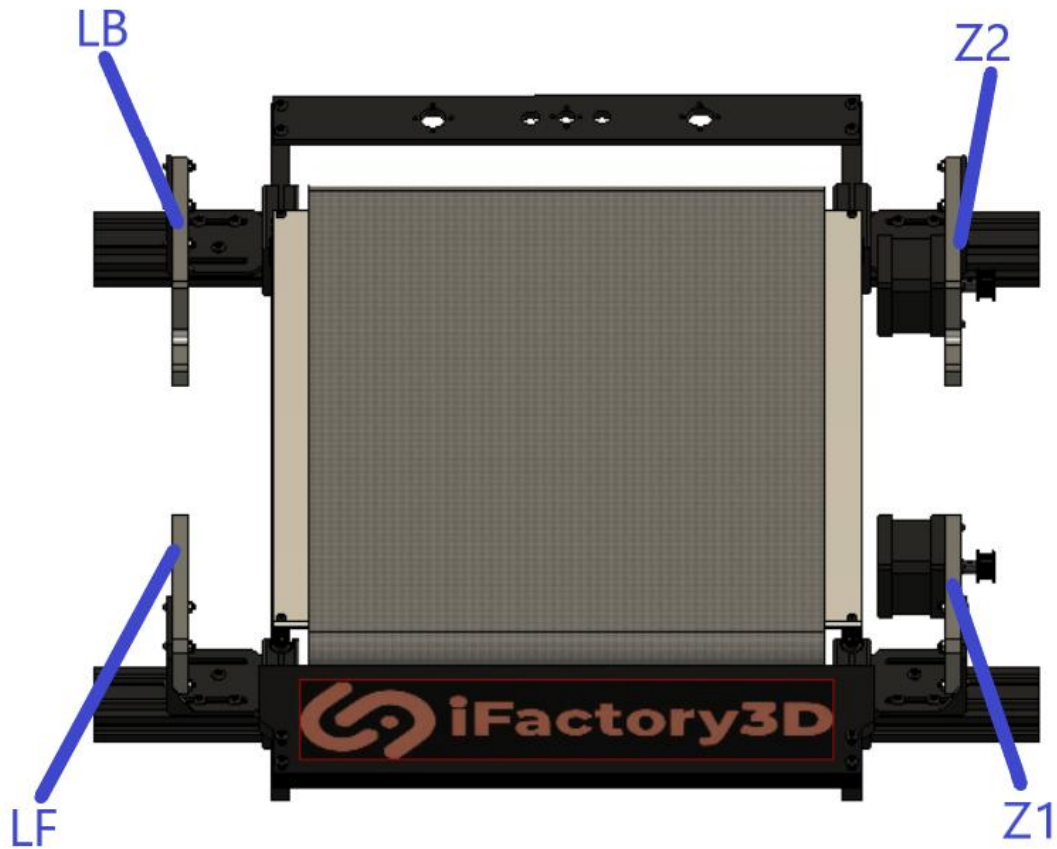

Now push the 20mm shafts into the bearings and through the belt. Start from the right site. The 20mm collars are placed on the between the bearings as shown in the picture. Push the shafts as far as the gear of the motor and the 20mm shaft are at the same level.

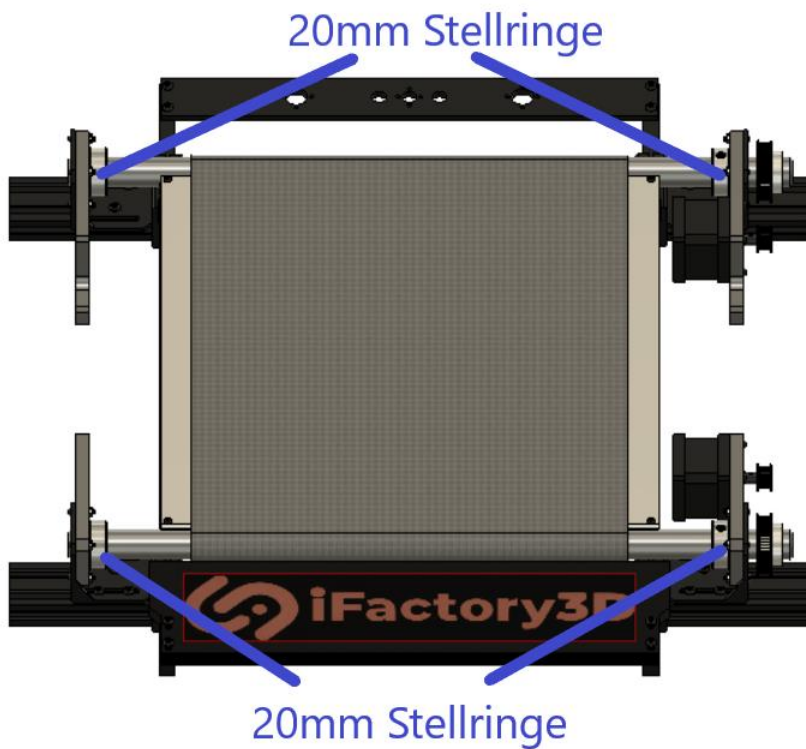

## Step 11: Tighten the Z belts

Place a 20mm GT2 belt around the gear from the 20mm shaft and the belonging motor gear.

Push the motor along the long holes and fasten the motor screws as soon as the Z belt has enough tension.

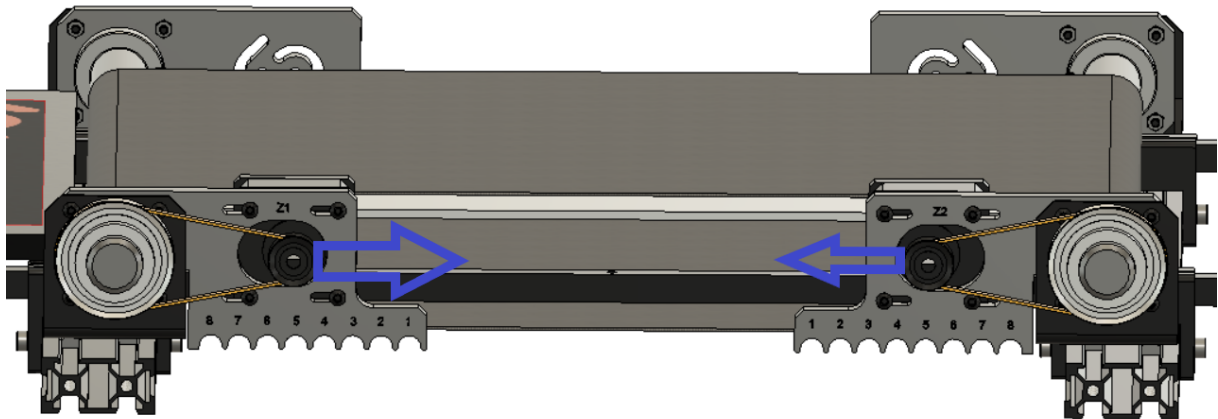

## Step 12: Mount the belt group.

Place the 20x40 profile of the belt group on the belt tightening sliders like before. Fasten the belt group and the belt tightening sliders with the 8 M5x25 screws.

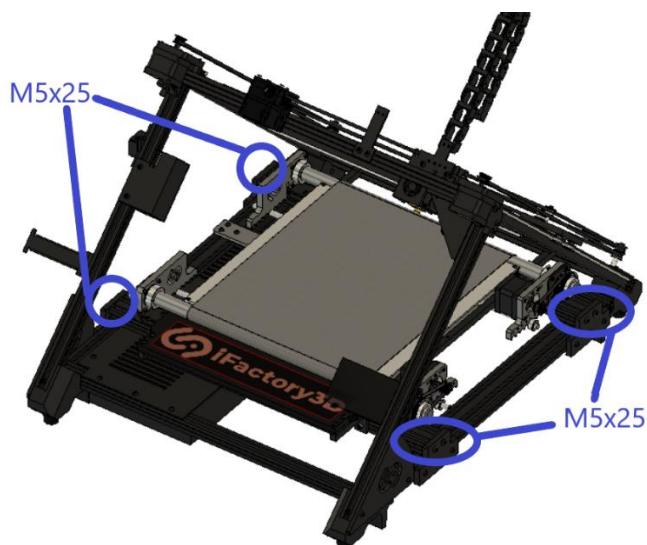

# Step 13: Tighten the Belt

Pull the two front belt tightening sliders in the direction of the side plates with the iFactory logo.

Fasten the sliders at a distance from 7mm between the slider and the side plates.

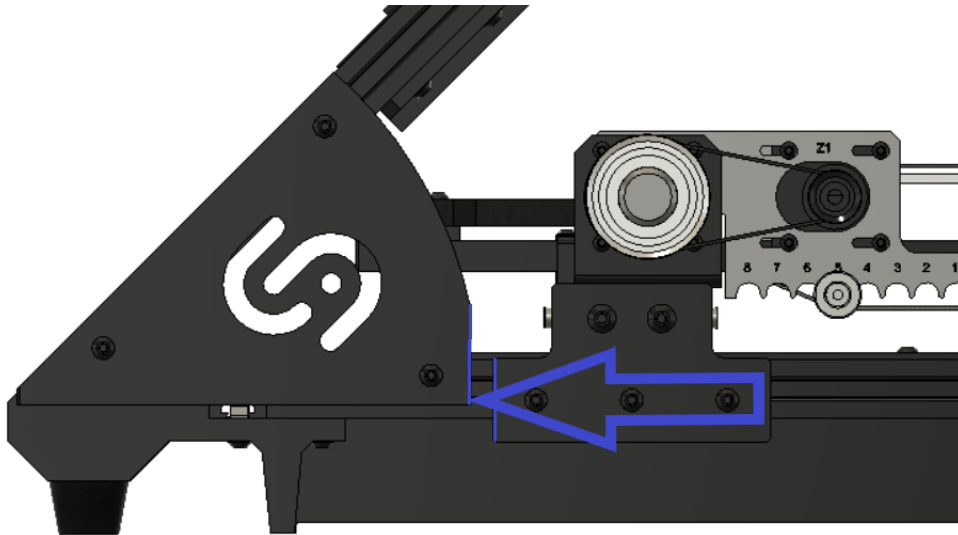

Now place the new 8mm Rods between the downside of the belt and the downside of the square bar and clip it into the fittings of the new bearing brackets. The fittings are numbered, and the rods need to be at the same number to apply the tension evenly to the belt. The higher the number of the fitting is more tension is applied to the Belt.

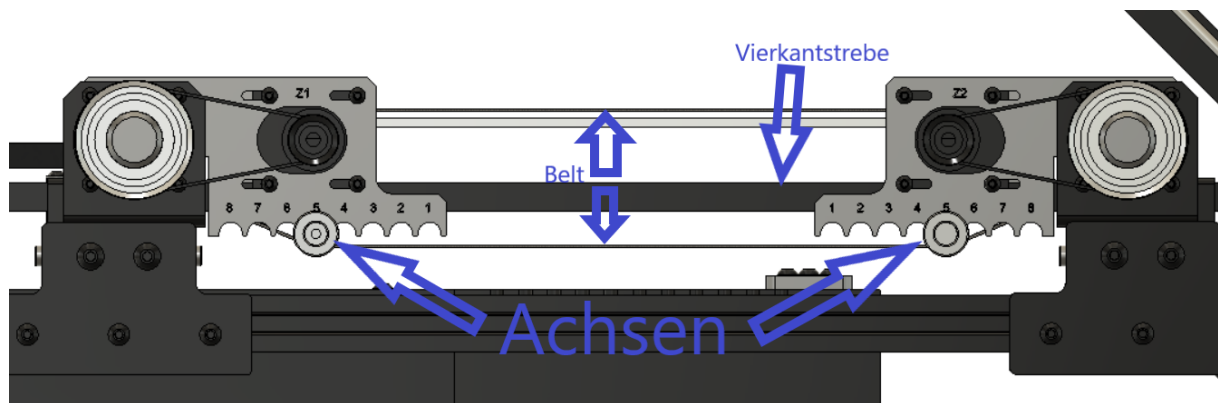



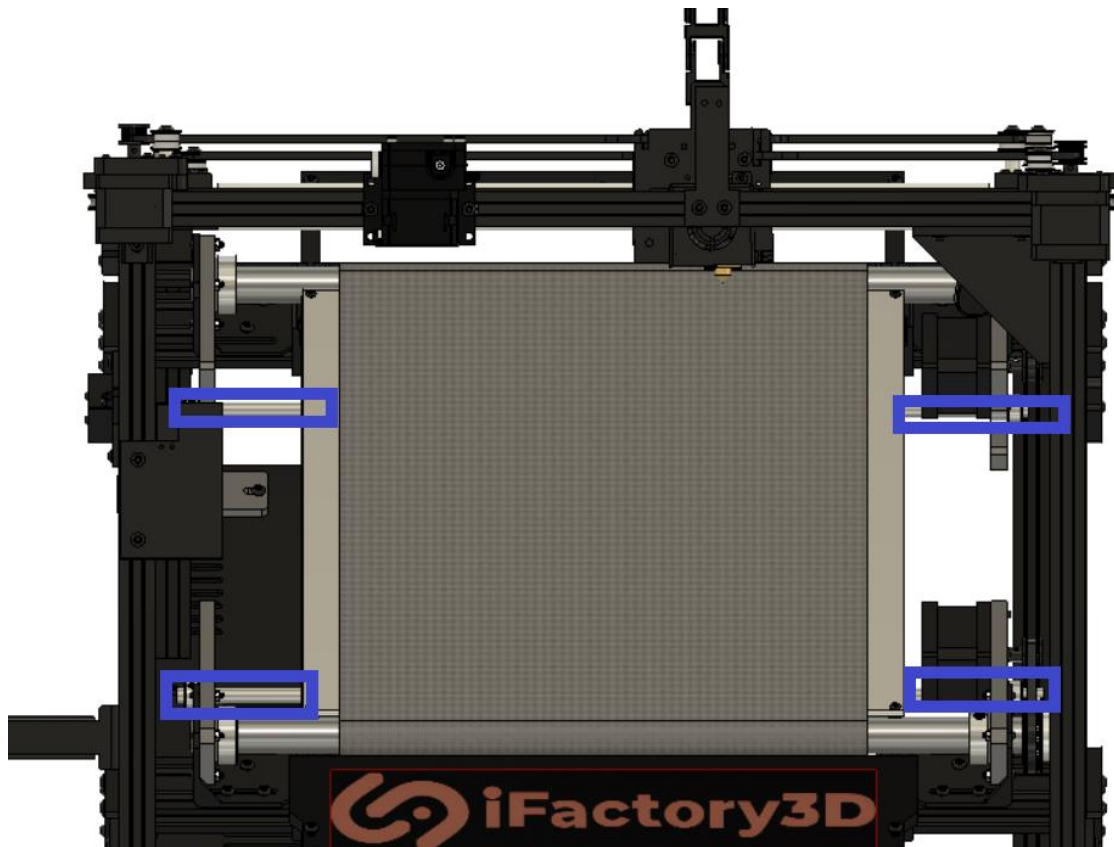

## Step 14: mount the new printed parts.

Dismantle the filament detection from your printer and its holder. Mount it to the new filament detection holder and mount it to the printer as before.



Mount the new camera holder in the top right 90° corner and clip the camera eye on it.

