

# iFactory One

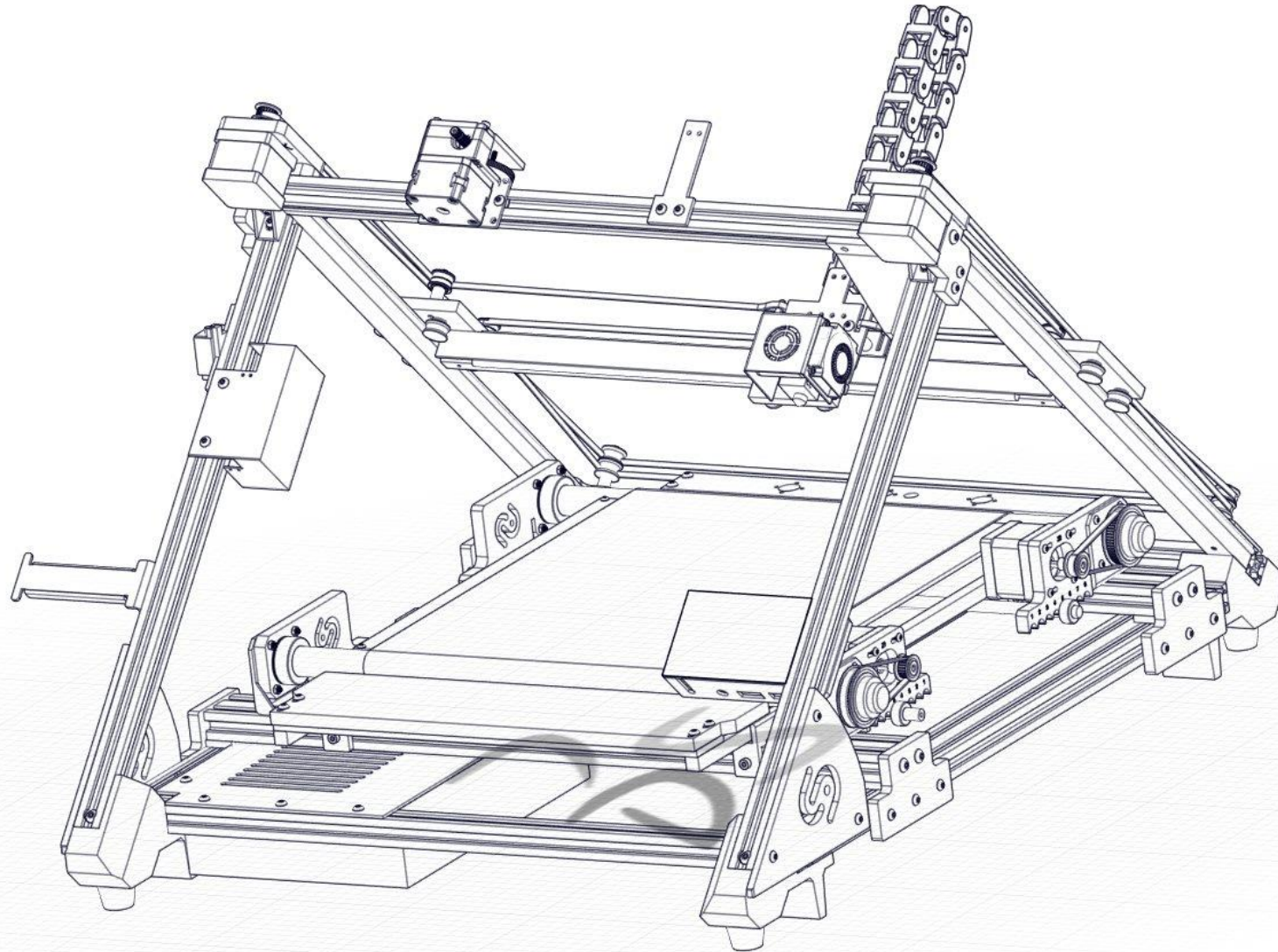

This is an early version of this manual. For the newest version, please visit: <https://ifactory3d.com/support/>

# General advice

For the assembly of many components of the iFactory One, so-called T-nuts are used. The T-nuts need to be pushed into the profile groove. This only works if the T-nut is in the correct position, as shown in the picture.

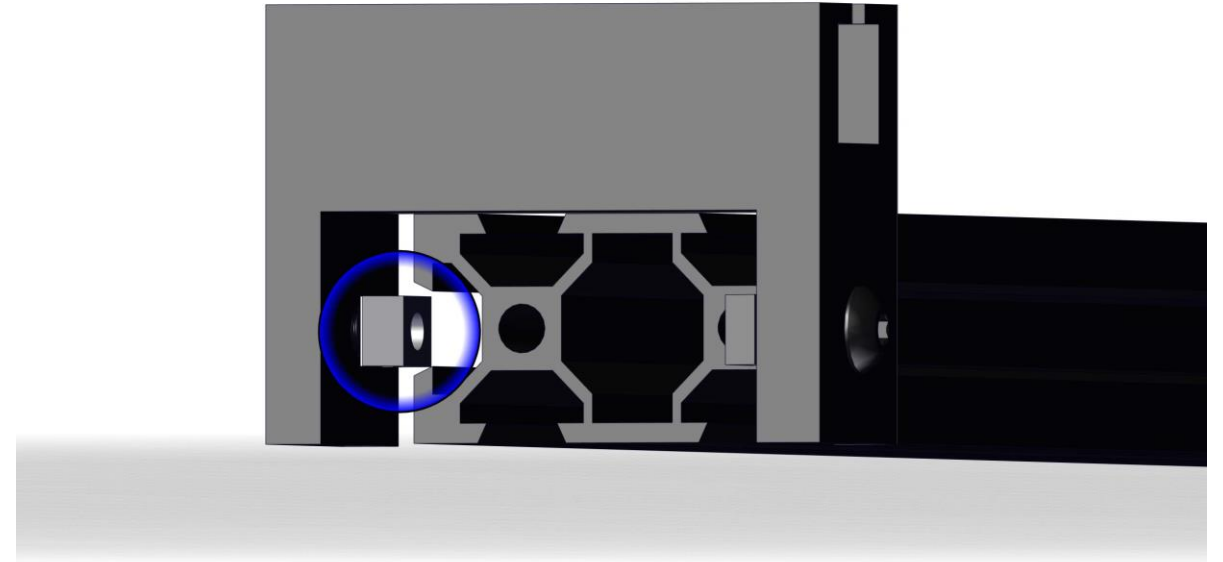

# General advice

Once the T-nut is in the groove and the component is in place, the screw can be tightened. To create the desired clamping, the T-nut must be turned 90° as shown in the picture.

It may happen that the T-nut does not turn in the groove when the screw gets tightened. If this happens, you should unscrew the screw a little (do not turn the screw all the way out because then you will lose the nut!) and then tighten it again until the T-nut produces the desired clamping.

In general, screws in plastic components should not be tightened too much, otherwise they can break (as soon as you hear noises, do not continue turning).

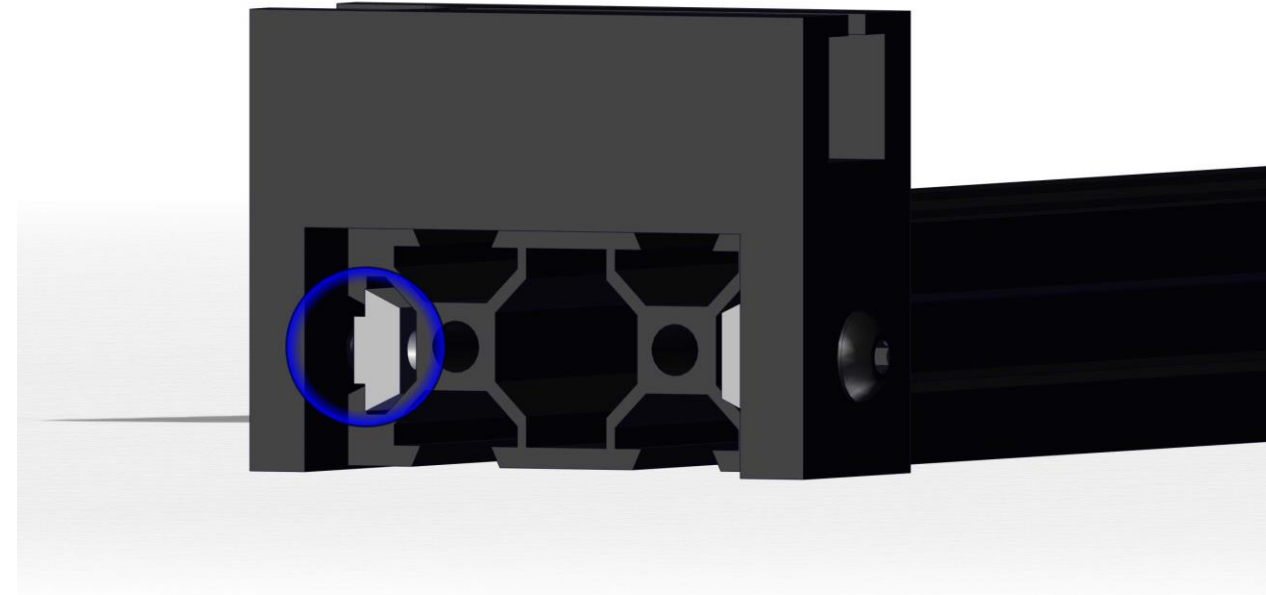

# Step 1

Feet and extrusions

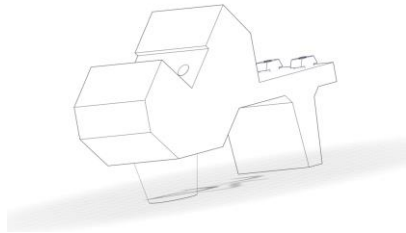

Foot LB

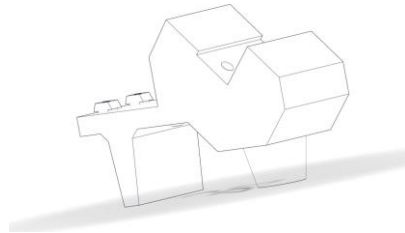

Foot RB



20x20 aluminum extrusions 530mm

Mount the back feet (LB, RB) on a 20x20x530 aluminium extrusion (without thread) with M5x25 screws.



# Step 2

## Corner bracket and guide rails



Corner bracket small L



Corner bracket small R



Guide rail

Mount the small corner brackets onto the two guide rails with M4X20 screws.

The two guide rails are packed in a plastic bag. One of them is labelled with an R or an L. Mount the small bracket R to the guide rail which had an L on its plastic bag.



# Step 3

Corner bracket and extrusions

Mount the two rails to the extrusion profile of step 1.  
Use the T-nuts from the corner brackets.

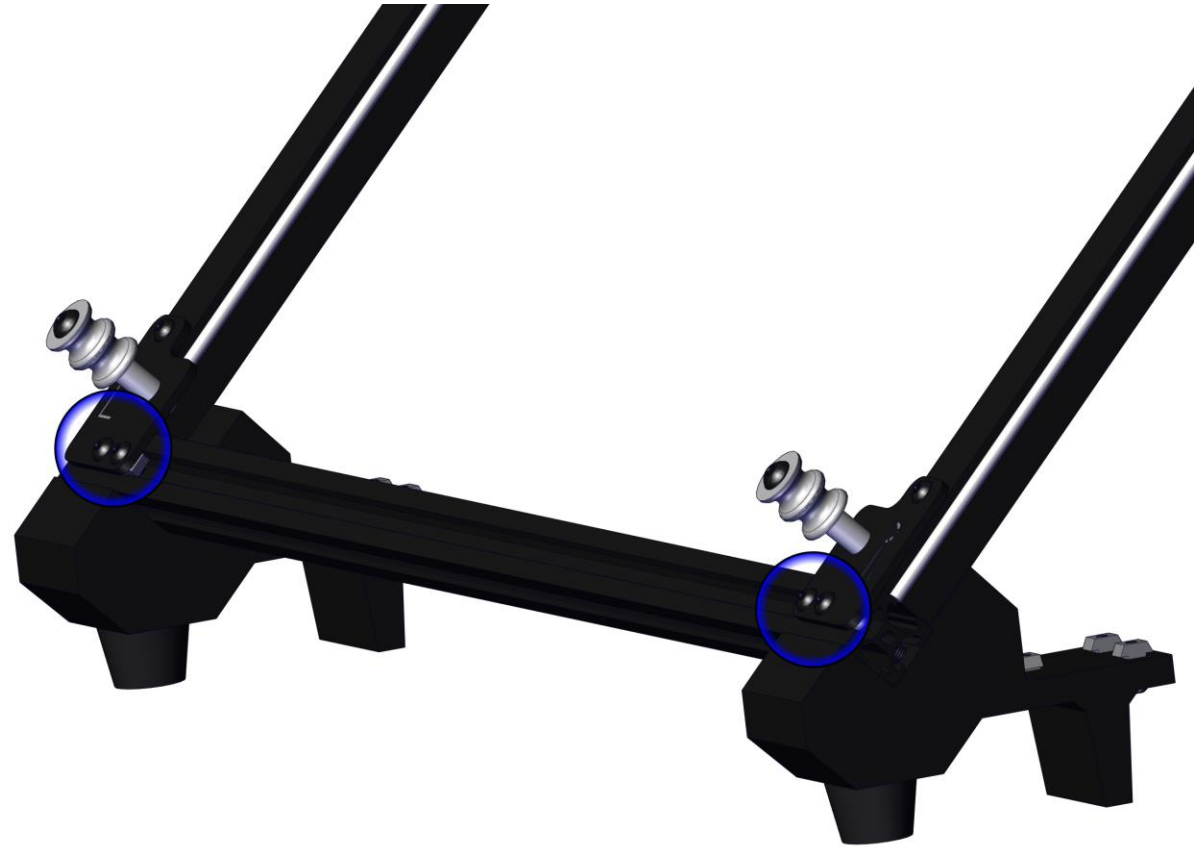

# Step 4

Printhead and guiderail

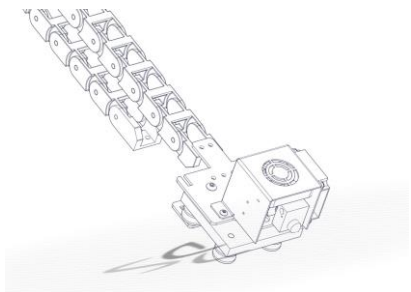

Printhead

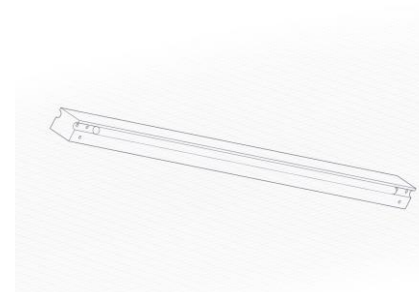

Guide rail printhead

Slide the printhead on the guide rail.



# Step 5

## Guiderail and slider

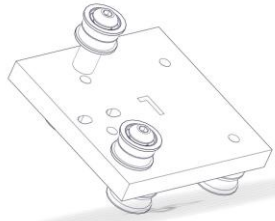

Slider L

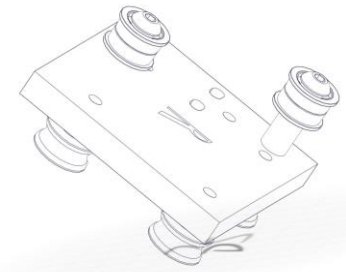

Slider R

Mount the sliders on the left and right side of the guide rail in the orientation as shown in the picture.

Use M4x20 screws.





# Step 6

Slider and guiderails

Slide the assembly from step 5 onto the guide rails.  
Now the left slider is on the side of the  
corner bracket R and the right slider is on the corner  
bracket L.



# Step 7

## Guiderails and extrusions



20x20x460 Extrusion

Mount the profiles on the assembly with M5x25 as shown in the picture. The corner must be at the top of the profile.



# Step 8

Extrusions and front feet

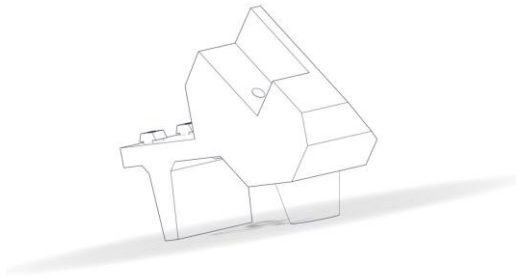

Foot LF

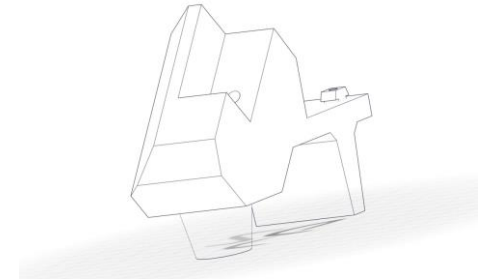

Foot RF

Mount the front feet (LF, RF) with M5x25 screws to the extrusions which have been mounted in the previous step.



# Step 9

Extrusion and corner

Mount the 20x20x530 extrusion with threads on the corners of the assembly from step 7. The holes in the profile should face the guide rail.

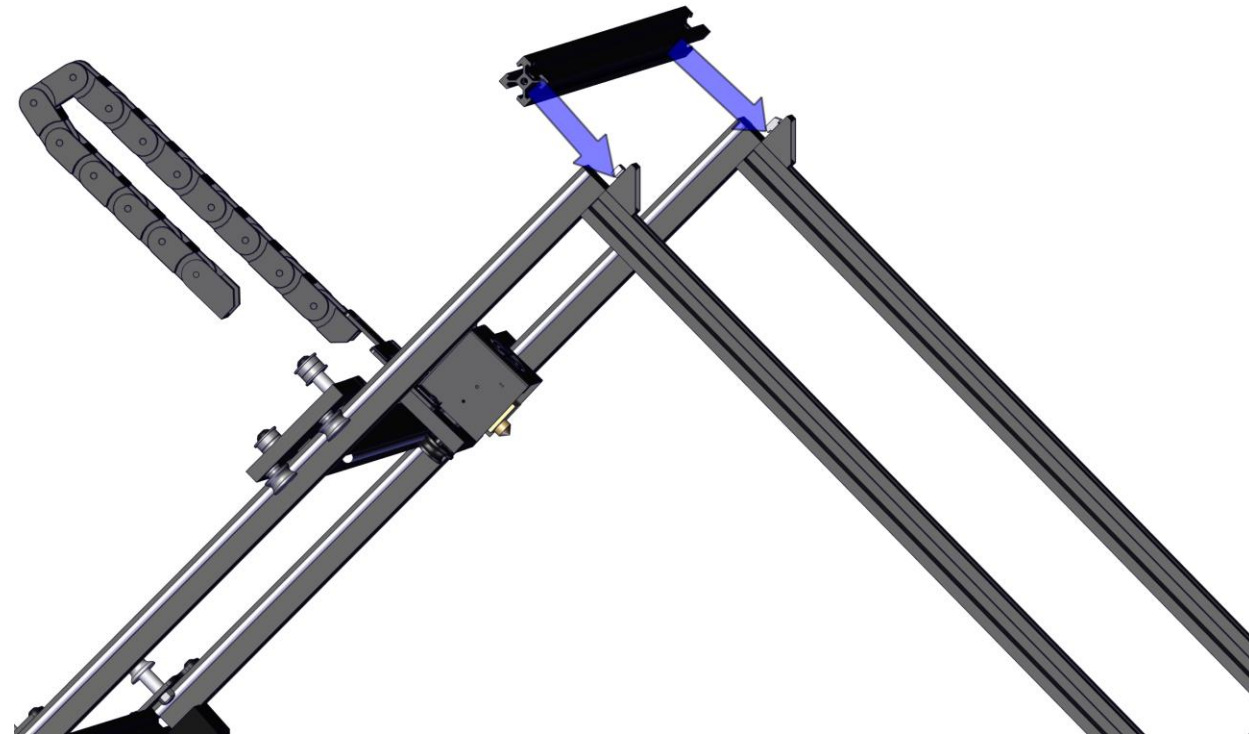

# Step 10

Extrusion and motors

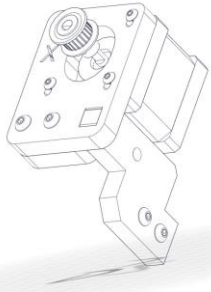

X-motor

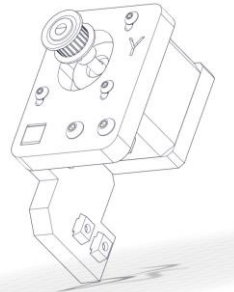

Y-motor

Slide the X and Y motors on the top 20X20x530 extrusion until the T-nuts from the motorbracket hit the channel of the 20x20x460 extrusion.



# Step 11

Y-motor brackets and screws

After the motors have been placed, tighten the circled screws shown in the picture and a M5x25 screw from the side.



# Step 12

X-motor brackets and screws

After the motors have been placed, tighten the circled screws shown in the picture and a M5x25 screw from the side.



# Step 12.5

Aligning the wheels

Check, if the printhead moves smoothly upwards and downwards. If it does, go directly to step 13.

If the rail does not move smoothly, follow the following steps:

The wheels that should be adjusted are the eccentric wheels, indicated with arrows in the picture.

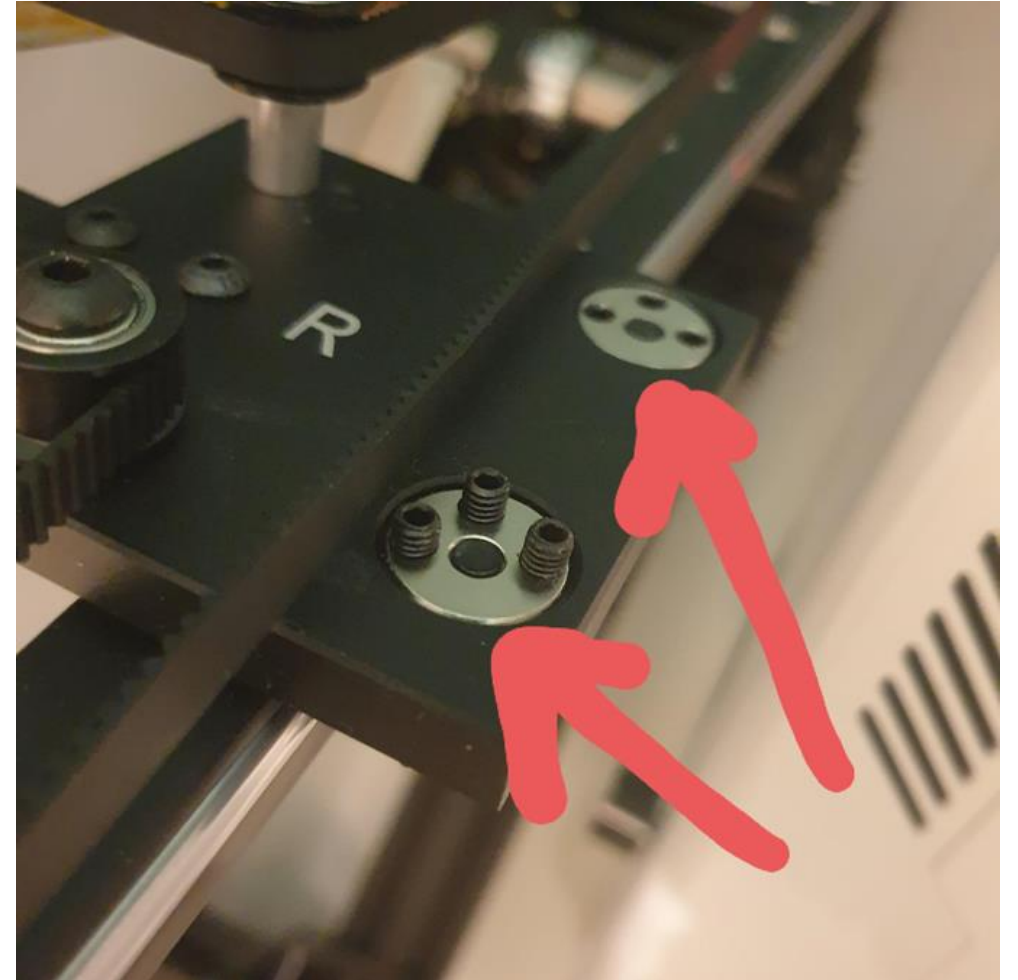



# Step 12.5

Aligning the wheels

First loosen the set screws (no need to do it as far as in the picture but just a bit).

Try loosening the bolt on the other side at the wheel.

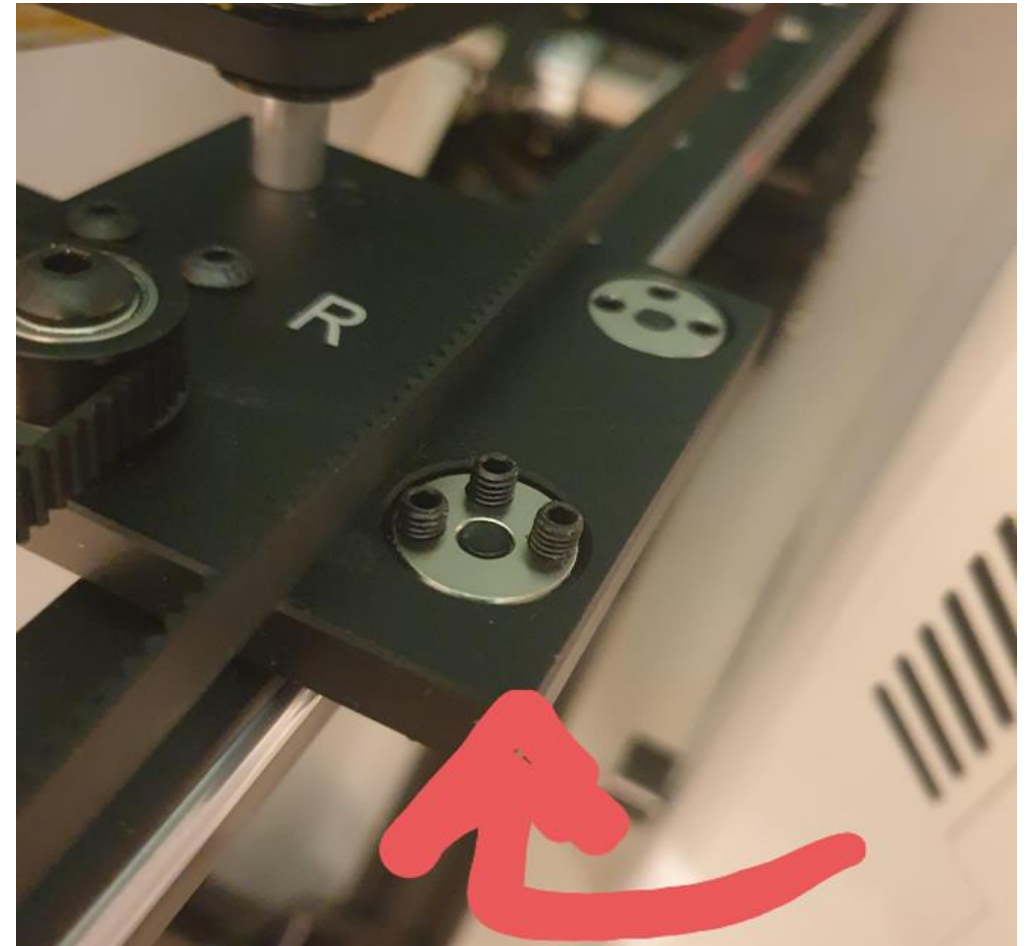

# Step 12.5

Aligning the wheels

You can fasten the bolt again, when you have placed the x rail onto the frame. Fastening the bolt again automatically realigns the wheel (it rotates along with the bolt until the wheels hit the rail). Then fasten the set screws.

If the bolt doesn't really want to come loose, you can try to rotate the disc with the eccentric hole. This may take some force, if the bolt is tight.

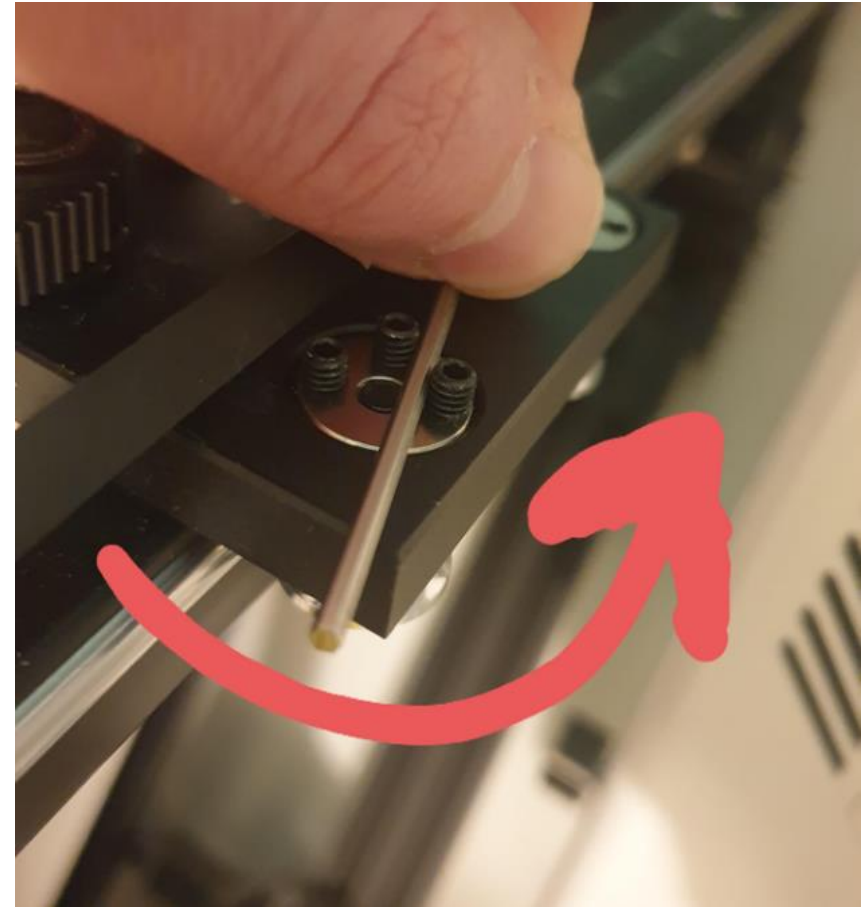

# Step 13

40x20 extrusions and 20x20 extrusion

40x20x530 extrusion

Screw two 40x20 extrusions to the 20x20 extrusions using the M5x25 screws as shown in the picture.

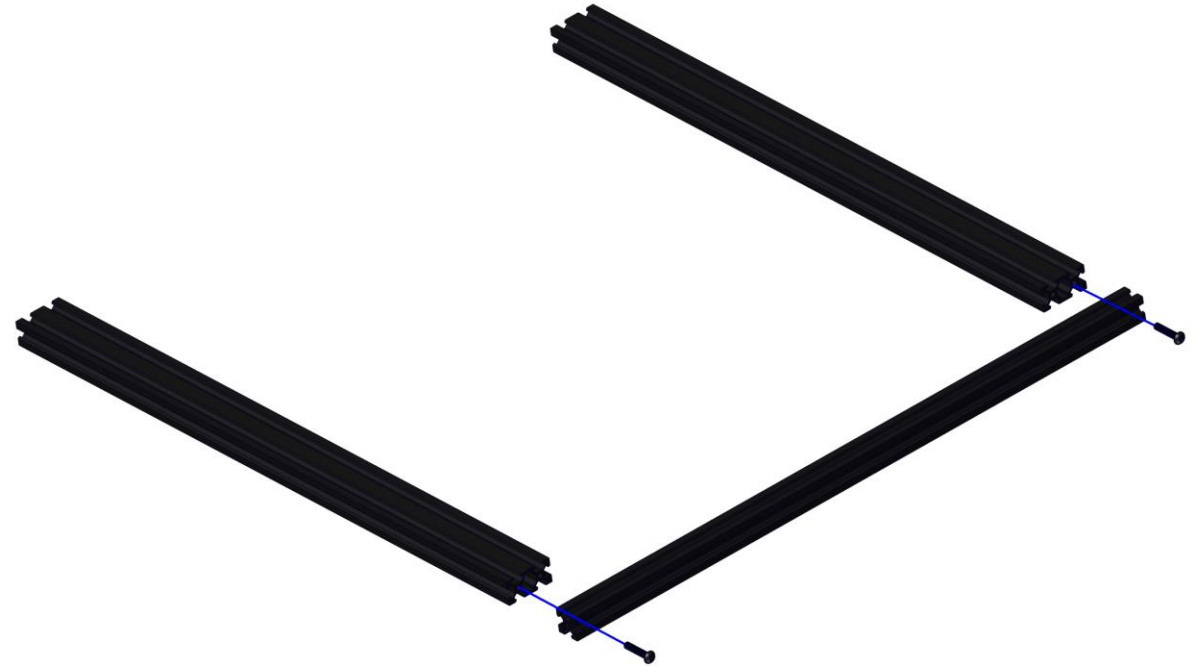

# Step 14

Belt tightening sliders and 40x20 extrusions

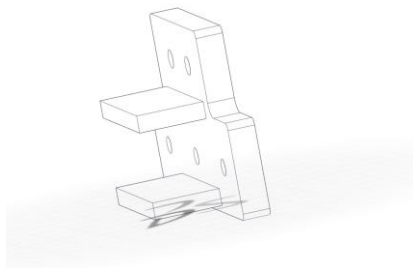

Belt tightening sliders

Slide 6 sliding blocks into the side channels of the 40x20 extrusions (yellow arrows).

Then mount two belt tightening sliders to each 40x20 extrusion.

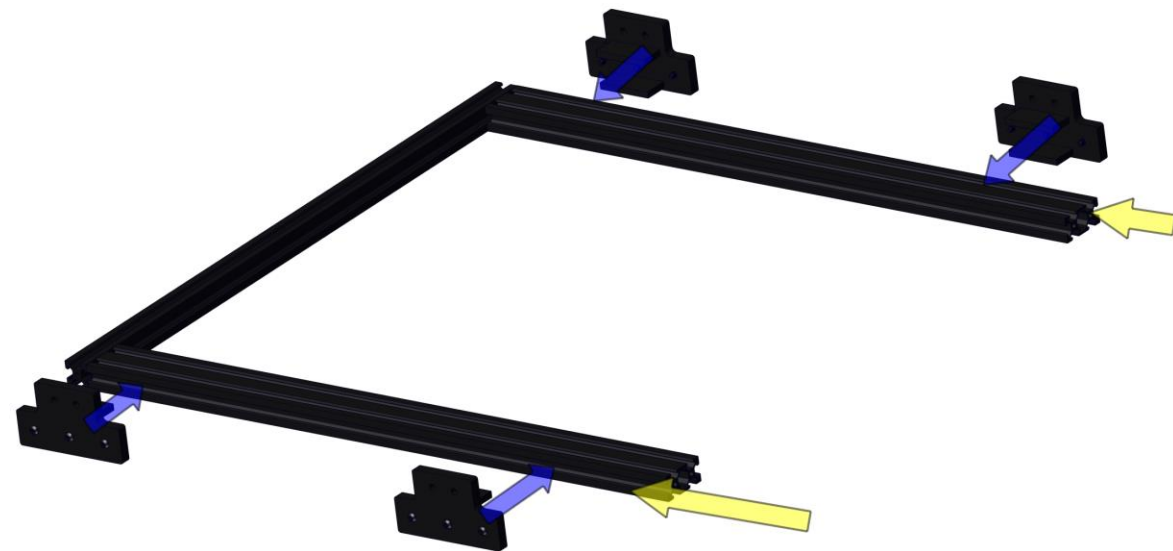

# Step 15

20x20 extrusion and 40x20 extrusions

Screw a 20x20 extrusion to both 40x20 extrusions using the M5x25 screws as shown in the picture.

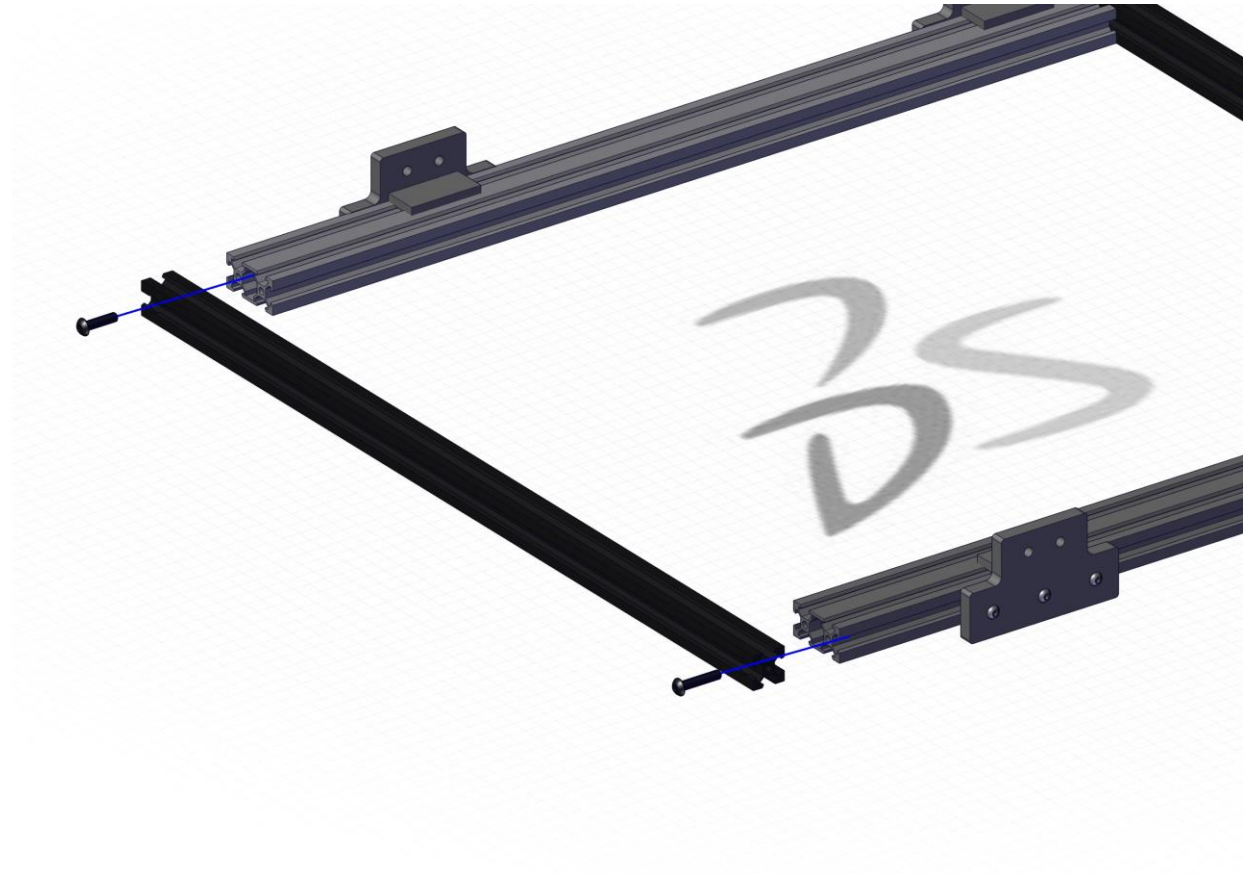

# Step 16

Assembly and assembly

Slide the assembly from step 15 into the assembly from step 12.

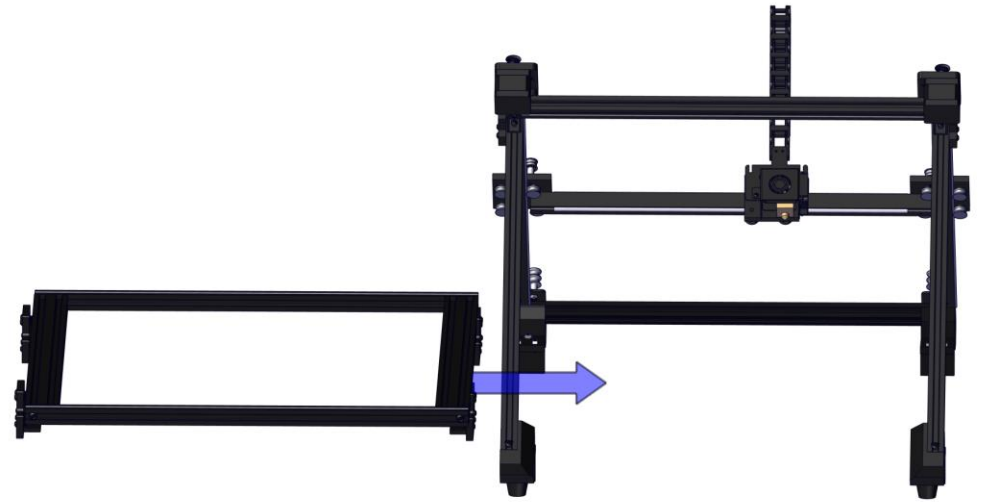

# Step 17

Assembly and placement

Place the corners of the assembly from step 15 on each foot. Take care, that all T-nuts are placed inside the channels of the extrusions.



# Step 18

Assembly and mounting

If the assembly from step 15 is placed right, turn the printer on the side and tighten the three circled screws in every foot.

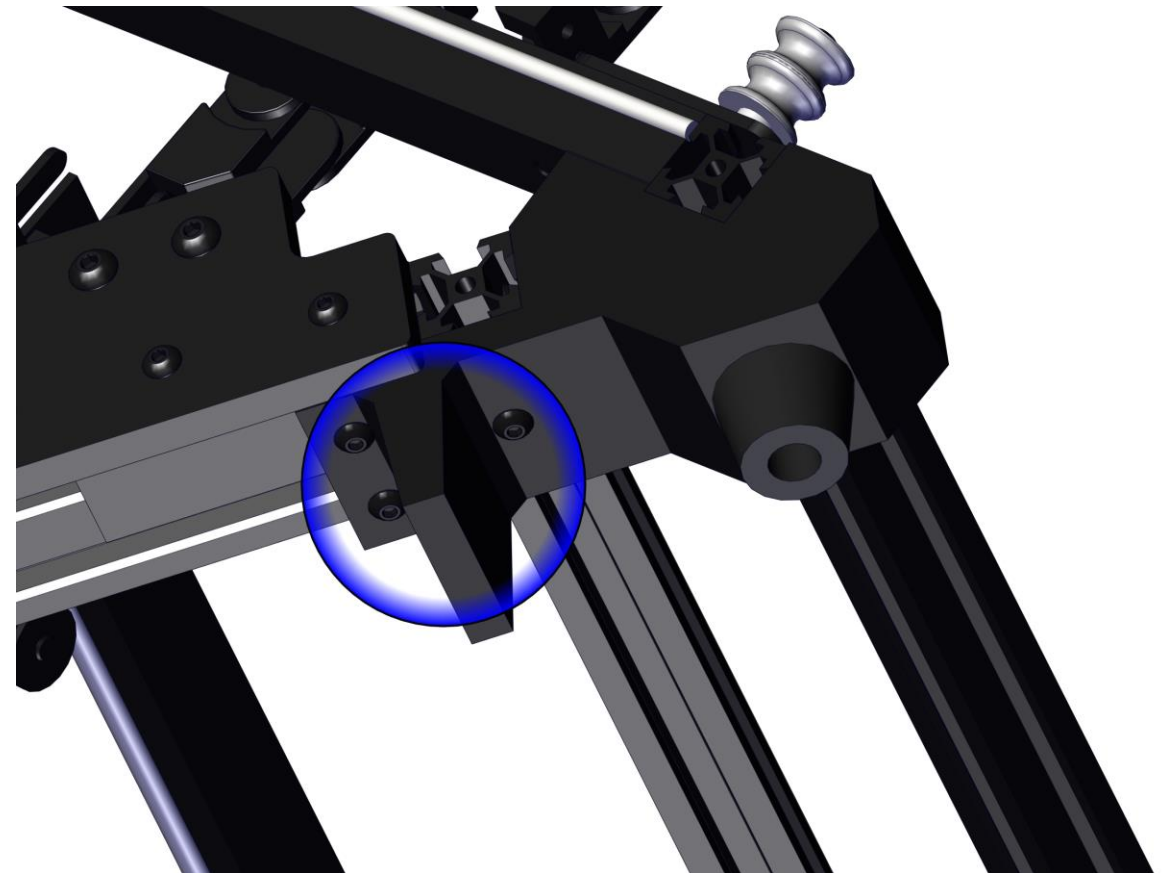



# Step 19

## Power supply and mainboard

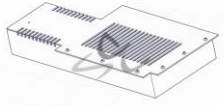

Power supply

First, check if the power supply is set to the correct voltage for your country. There is a switch on the power supply to adjust this.

Mount the power supply & mainboard on the front left corner with the pre-mounted screw and T-nuts.

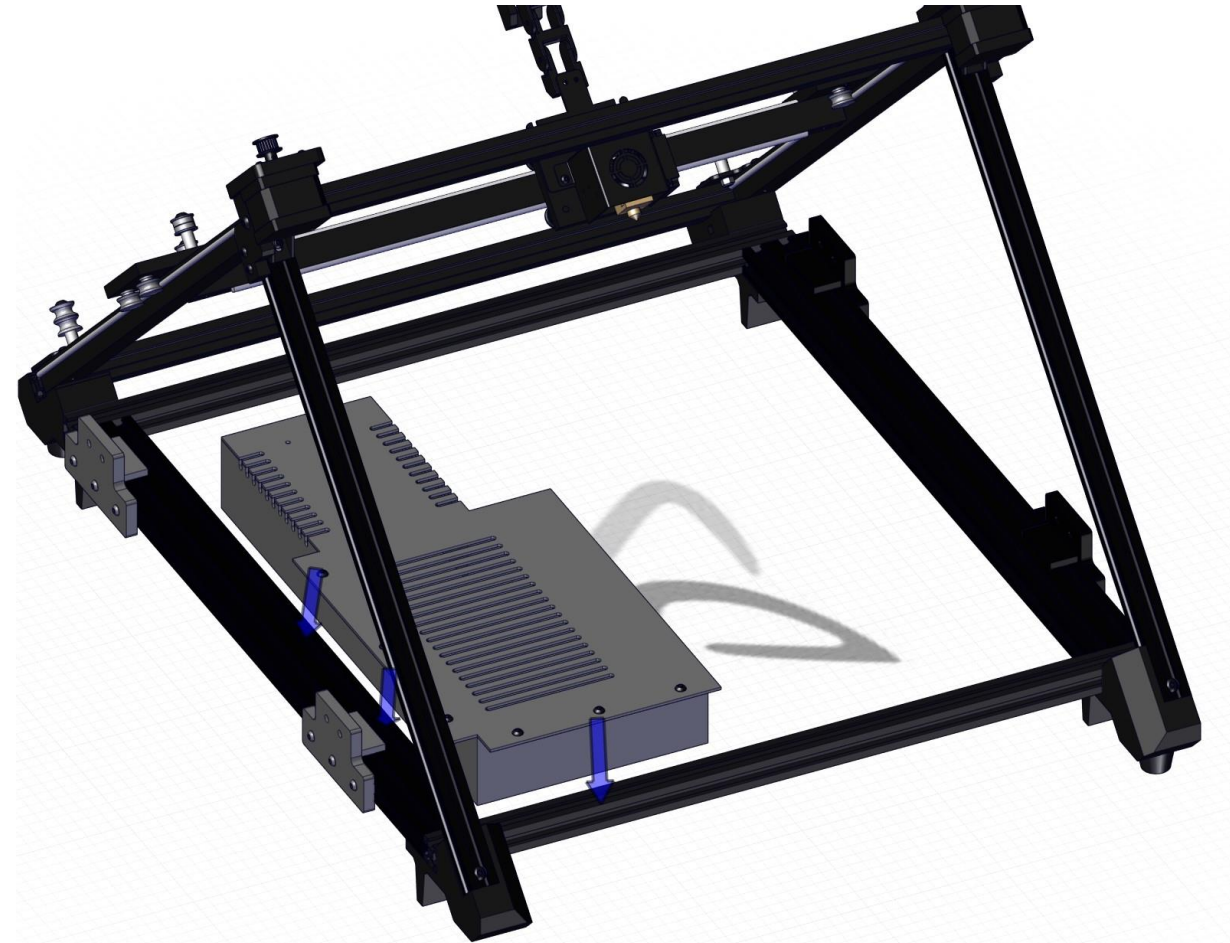

# Step 20

Belt and Y-motor

The next step is best done from the back of the printer. Place the gt2 belt over the Y-stepper motor pulley and then along all the other pulleys on the back - as shown in the picture - to build a core XY motion system. Mount the belt to the printhead with a cable tie.

Do not tension the belt too much, just prevent it from sagging.

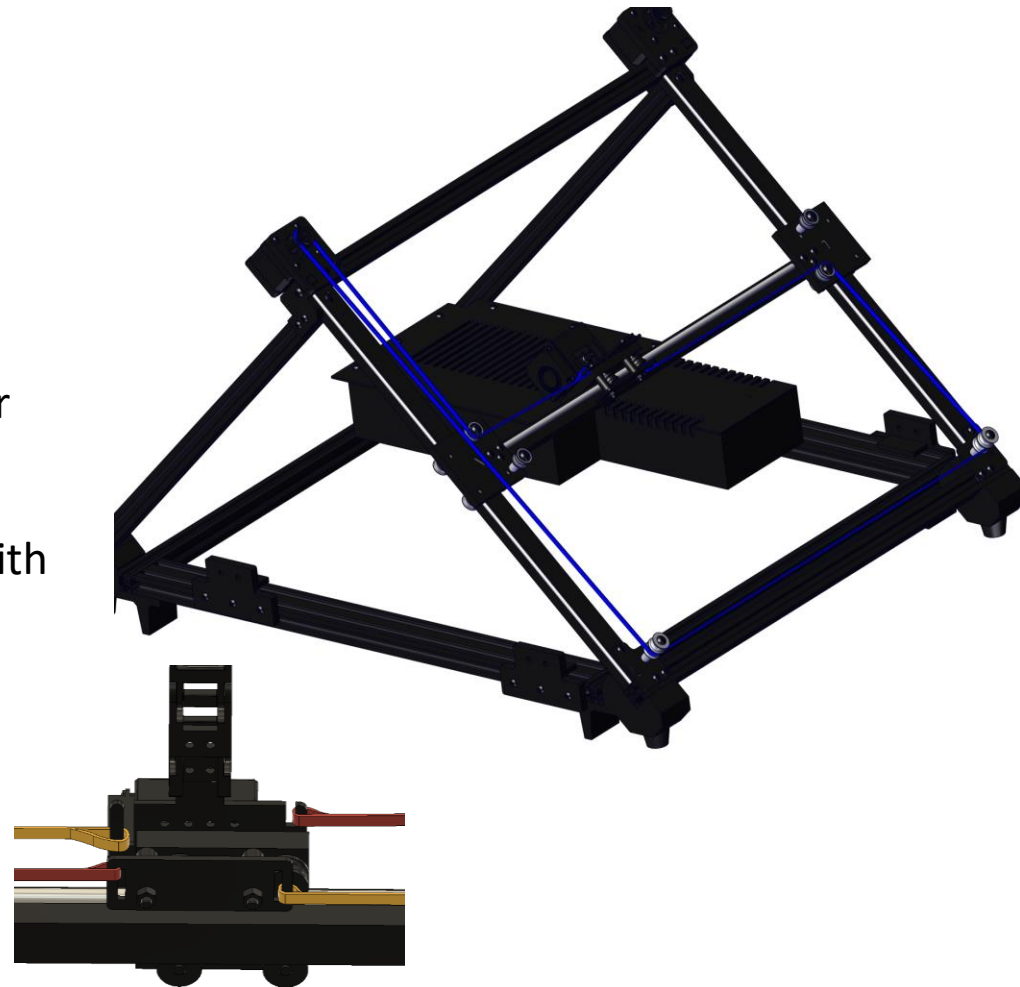

Yellow = Y

# Step 22

## Motors and belts

Release the four M3 screws in each motorplate.

Pull the motors upwards as shown in the picture and tighten the M3 screws again.

If the belt is not tensioned enough, release the four M3 screws again and repeat Step 20 and 21, but this time with more tension to the belts.

If the belts are tight enough, you can cut off the remaining gt2 belt at the printhead.

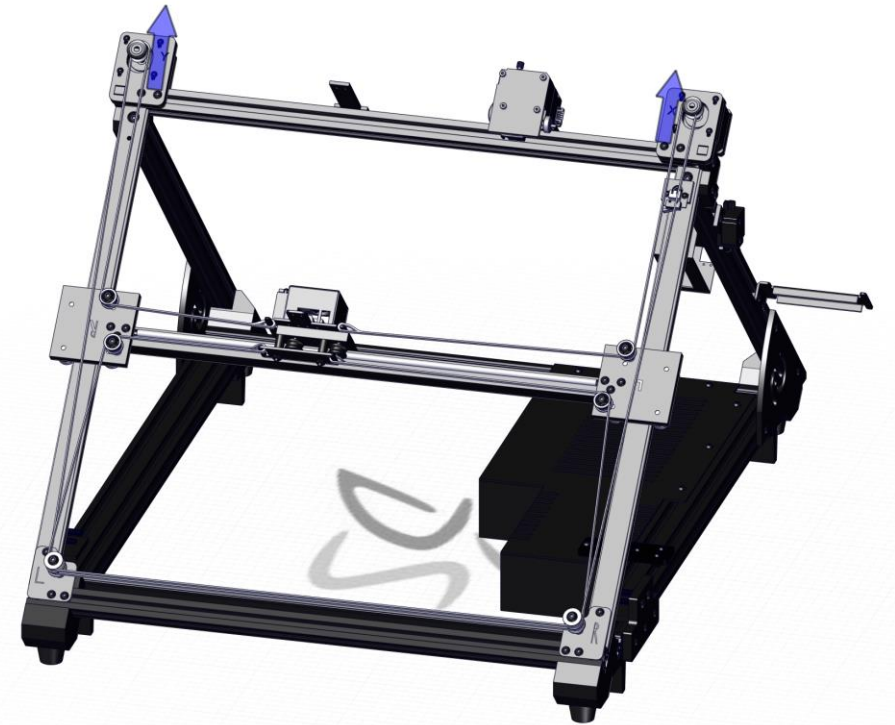

# Step 23

Square bars and connectors

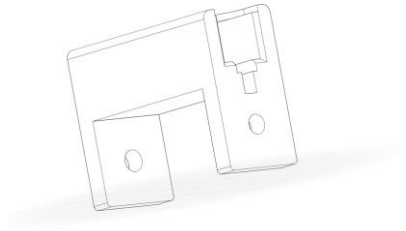

Connector



Square bars

Slide the connector brackets onto the square bars with the notches for the springs facing inwards.



# Step 24

## Square bars and metal plate

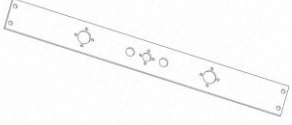

Metal plate with holes

Mount one metal plate with holes to the square bars using M4x12 screws.

Mount the plate on the side with the two additional threads (arrows).

Note: The metal plates are not symmetrical, but the alignment does not matter.

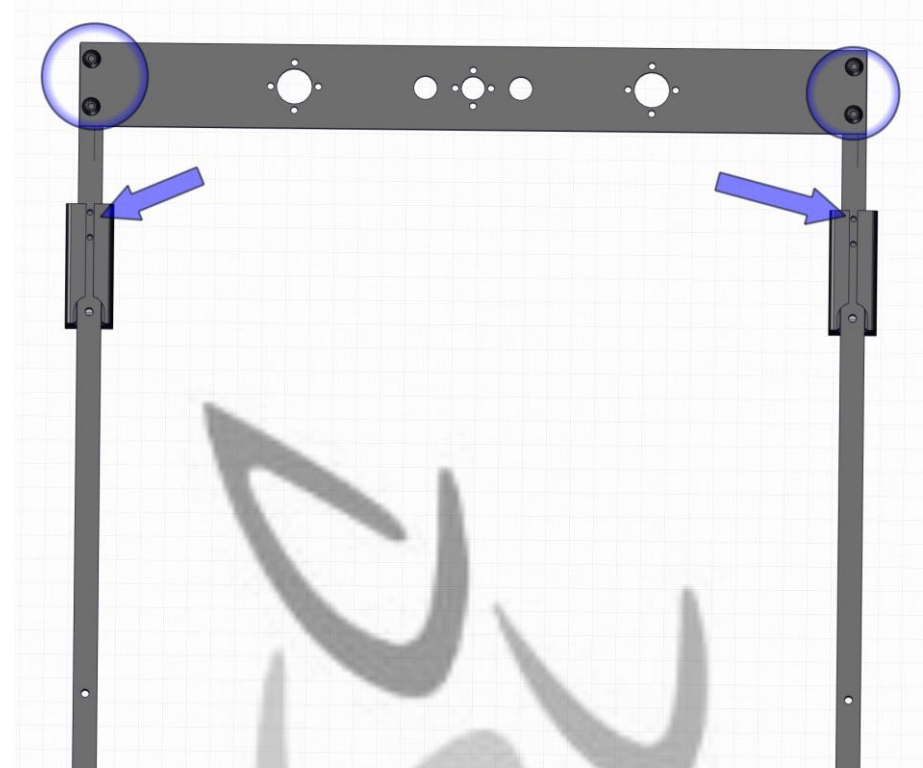

# Step 25

## Metal plate and scraper

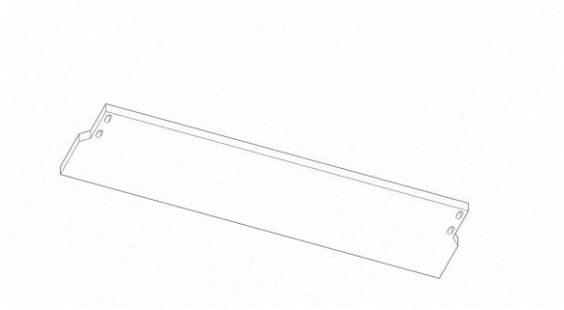

Scraper

Mount the other metal plate with holes and the scraper with M4x20 screws as shown in the picture. Before tightening the M4x20 screws, place the provided cloth between the scraper and the metal plate with holes. The scraper ensures that the parts come off from the belt and the cloth ensures that the parts do not fall into the printer.

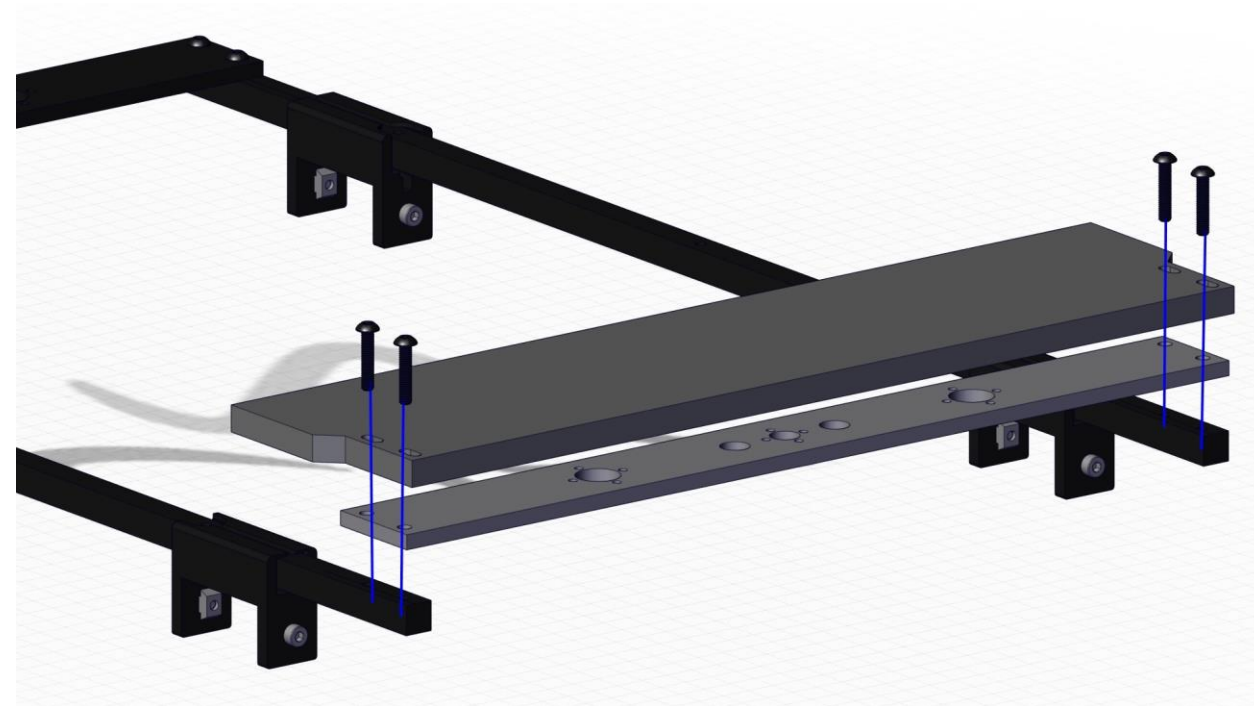

# Step 26

Heated bed and belt



Heated bed

Place the belt around the heated bed. Then mount the heated bed with a M3 screws, spacers, springs, and nuts as shown in the picture.

The heated bed must be positioned in such a way that the cables are at the front left.

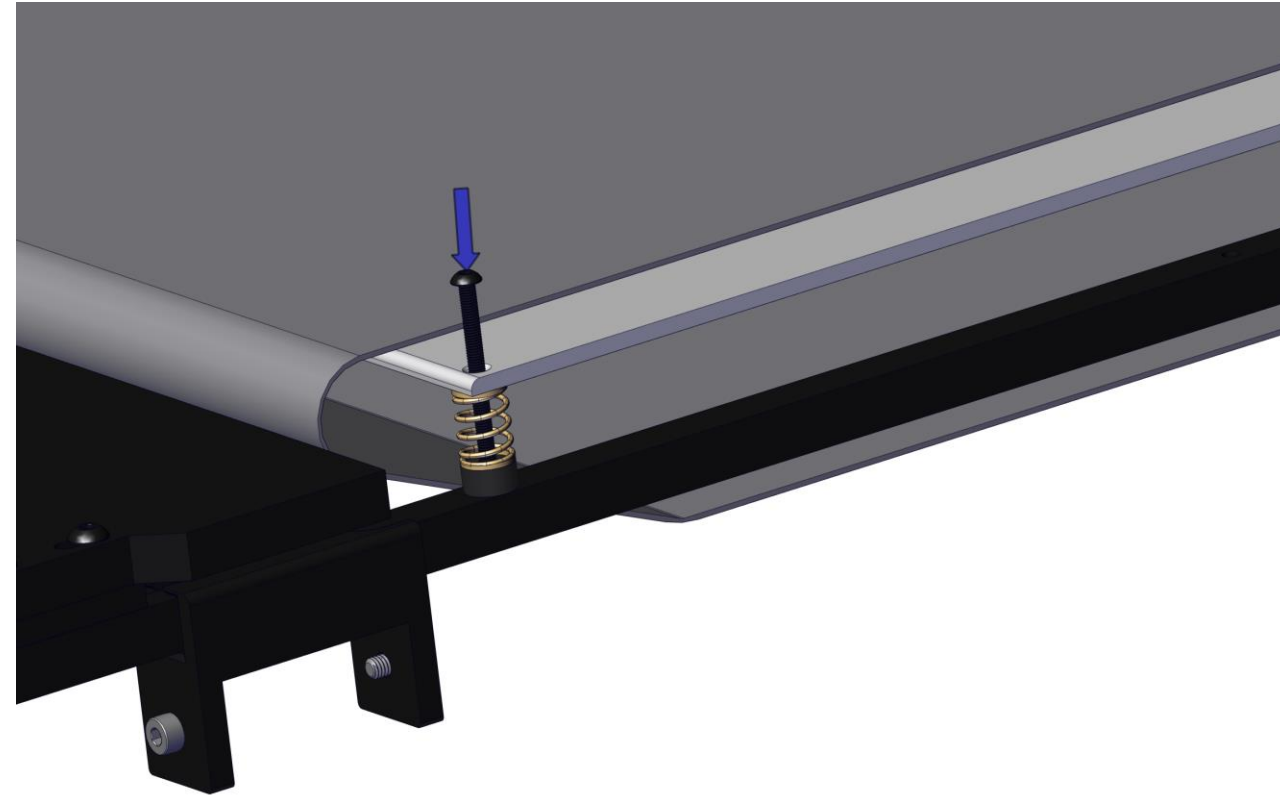

# Step 27

Heated bed and springs

Repeat step 26 for all corner of the heated bed.

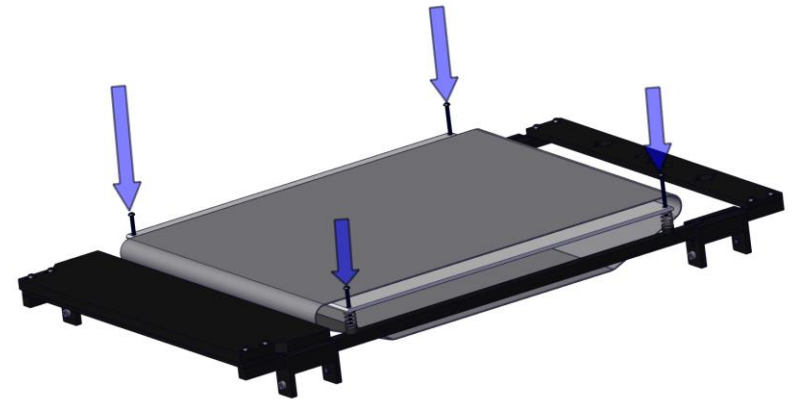



# Step 28

40x20 extrusion and connectors



40x20x530 extrusion

Slide the 40x20 extrusions into the connector brackets.

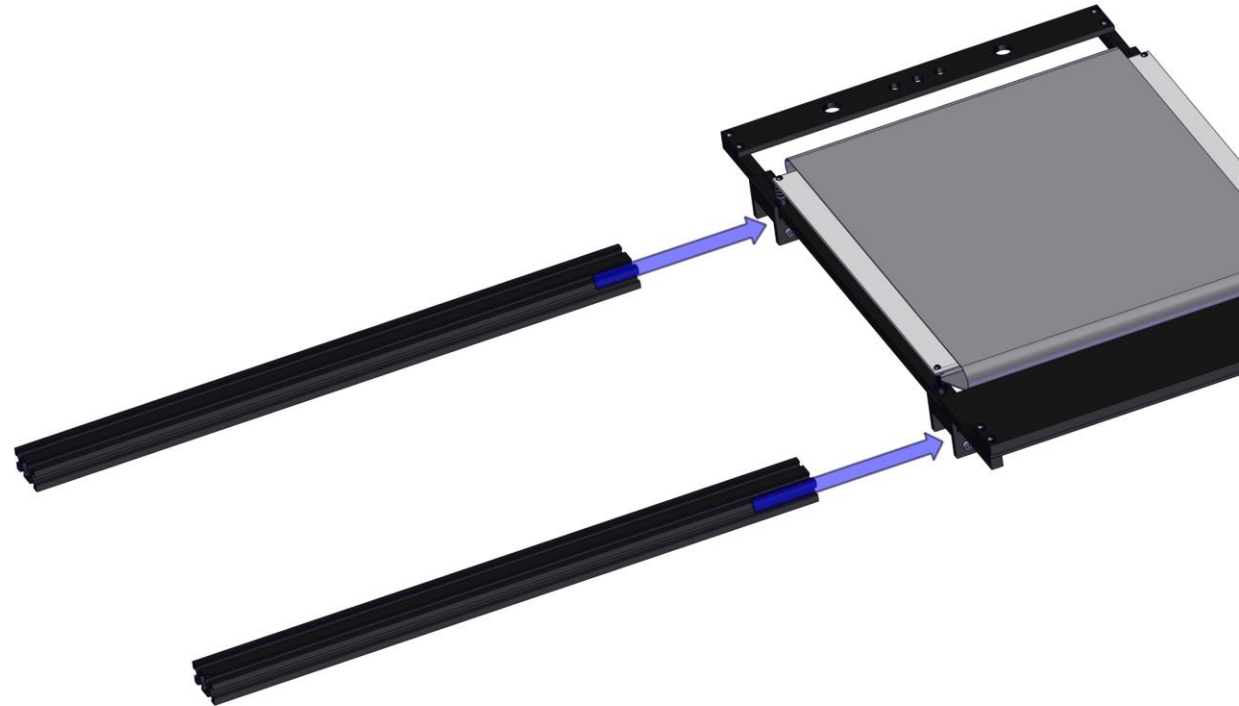

# Step29

## Connectors and distance

The distance between the end of the extrusion and the connector should be 95mm on each side.

If the extrusion is placed right, tighten the M4 screws in the connectors.

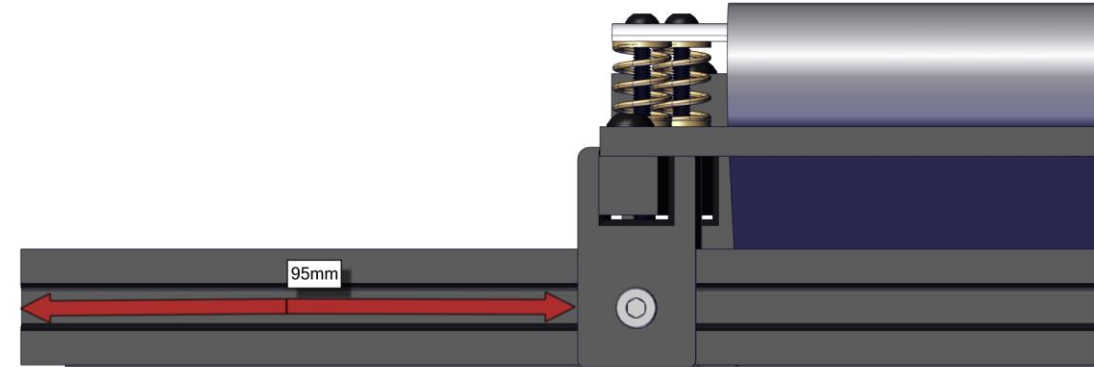

# Step 30

Extrusions and motors

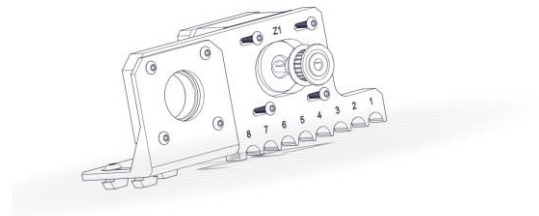

Z1 brackets

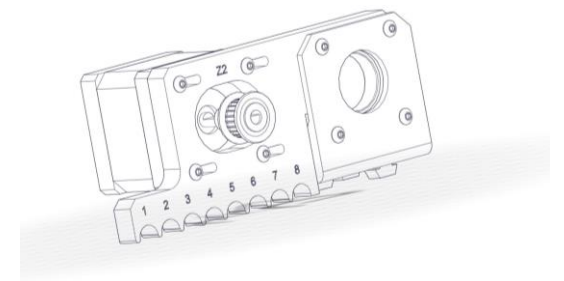

Z2 brackets

Mount the motor brackets Z1 and Z2 to the right side of the 40X20 extrusions as shown in the picture.

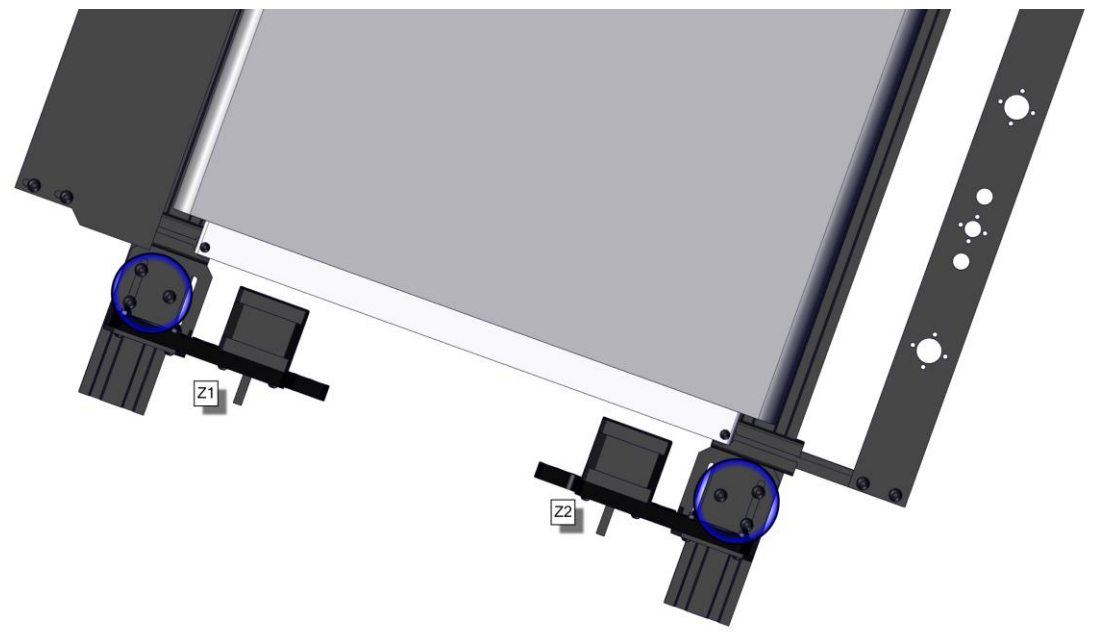

# Step 31

Extrusions and bearings

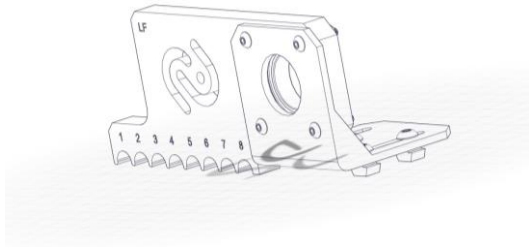

LF

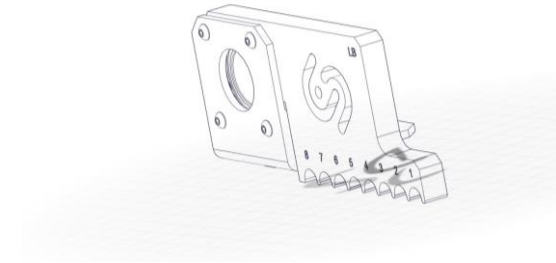

LB

Mount the bearing bracket LF and LB to the left side of the 40x20 extrusion as shown in the picture.

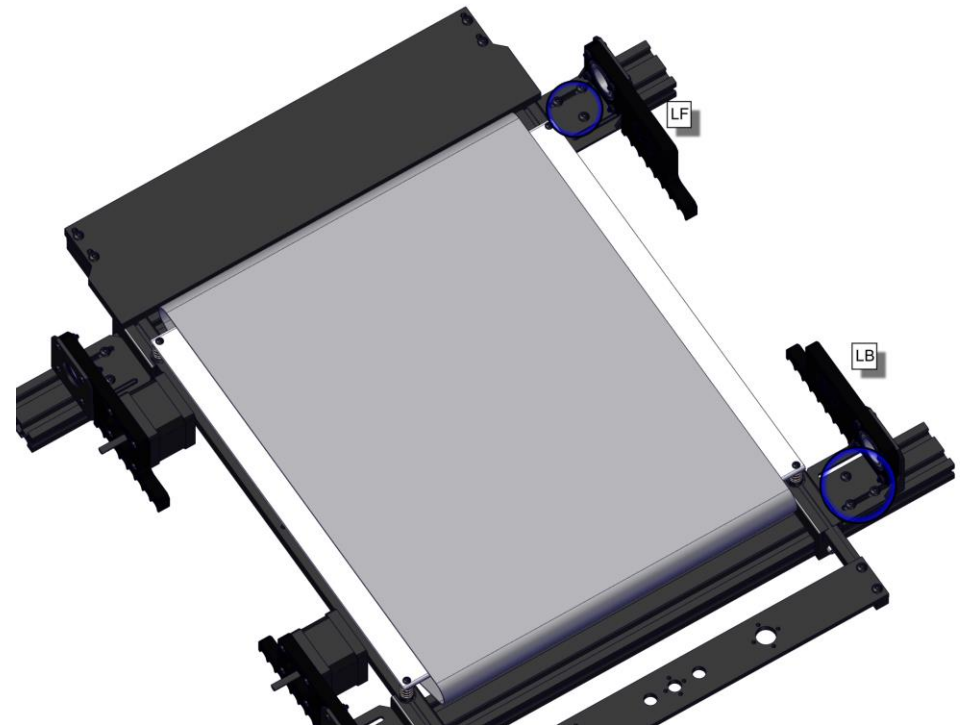

# Step 32

## Shafts and bearings

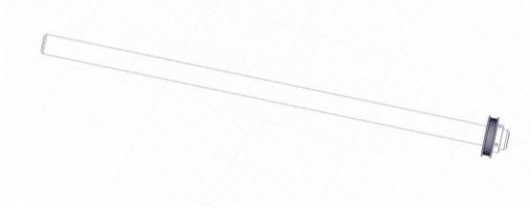

20mm shafts

Now push the 20mm shafts into the front bearings and through the belt. Start from the right side. The 20mm collars are placed between the bearings and the belt as shown in the picture.

Push the shafts until the gear of the motor and the 20 mm shaft are at the same height.

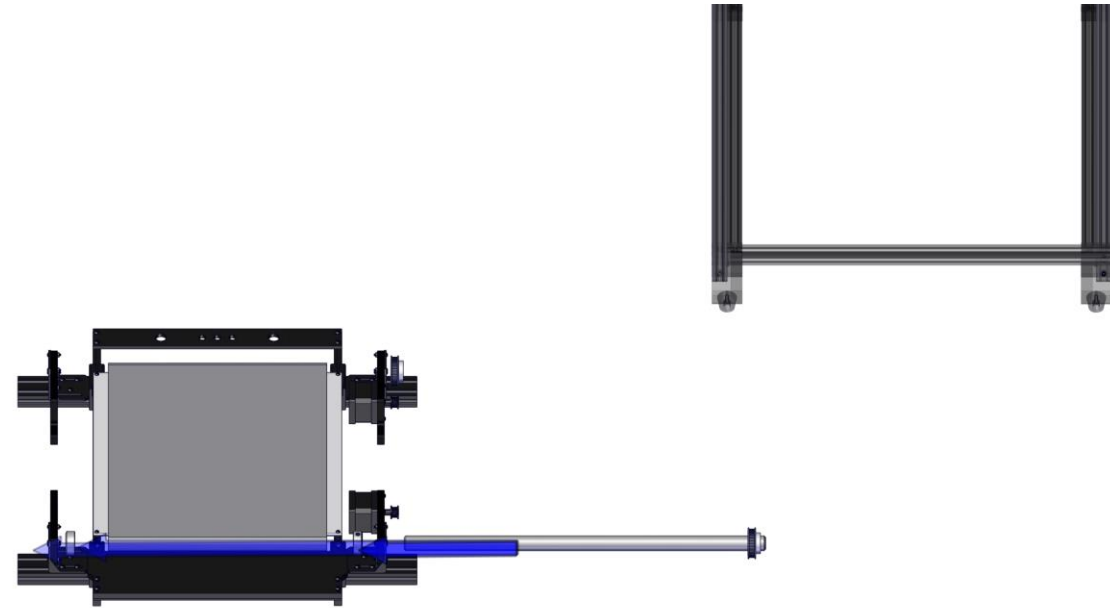

# Step 33

Shafts an collars

As soon as the shaft is placed right, slide the collars to the bearings and tighten the headless screw.

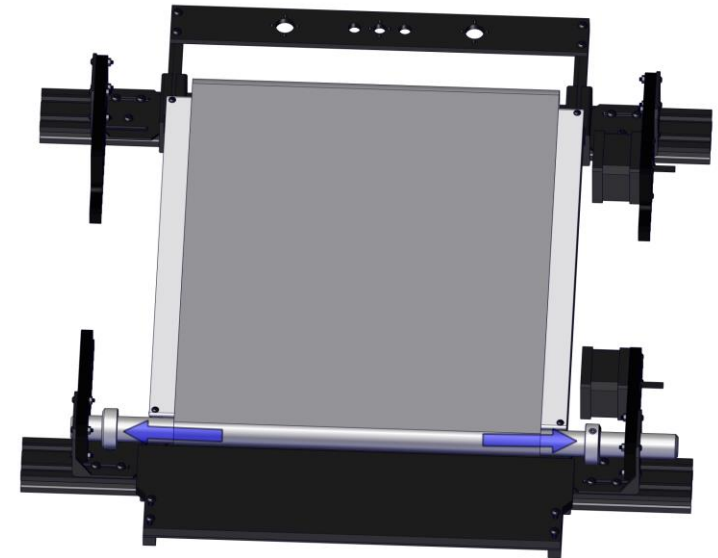

# Step34

Back shaft

Repeat step 32 and step 33 with the back shaft.

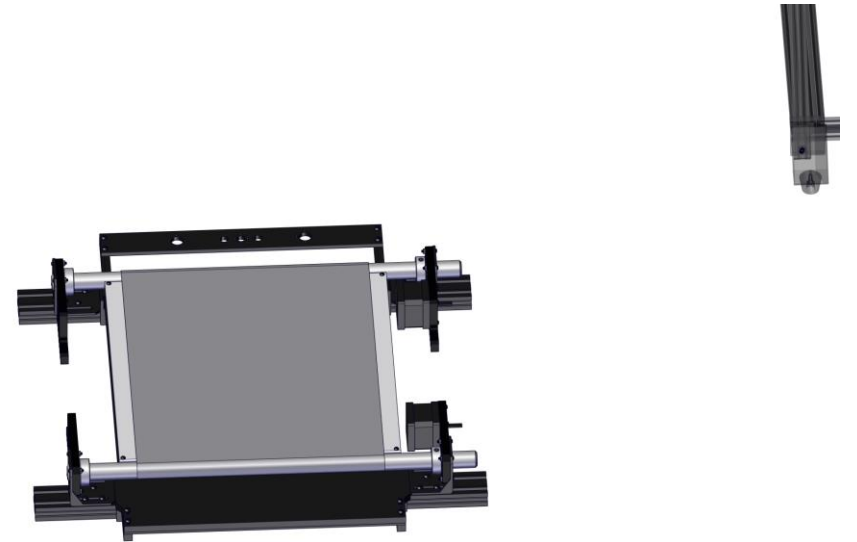

# Step 35

Motors and brackets

Release the M3 screws in the Z1 and Z2 motorplates.

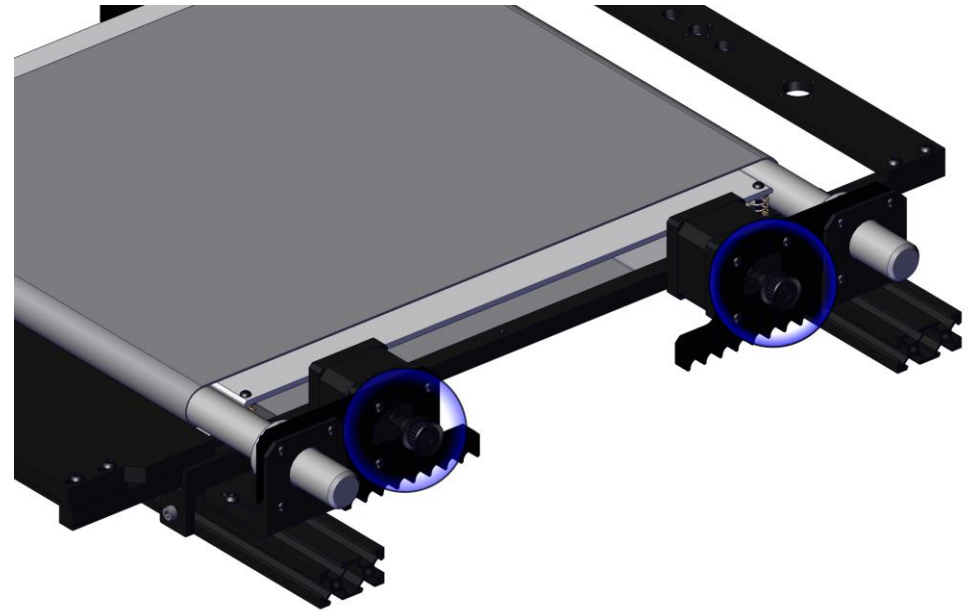



# Step 36

Belts and motors

Place a 20mm gt2 belt around the gear of the 20mm shaft and the associated motor gear.

Slide the motor along the slotted holes and fasten the motor screws once the Z-belt has sufficient tension.

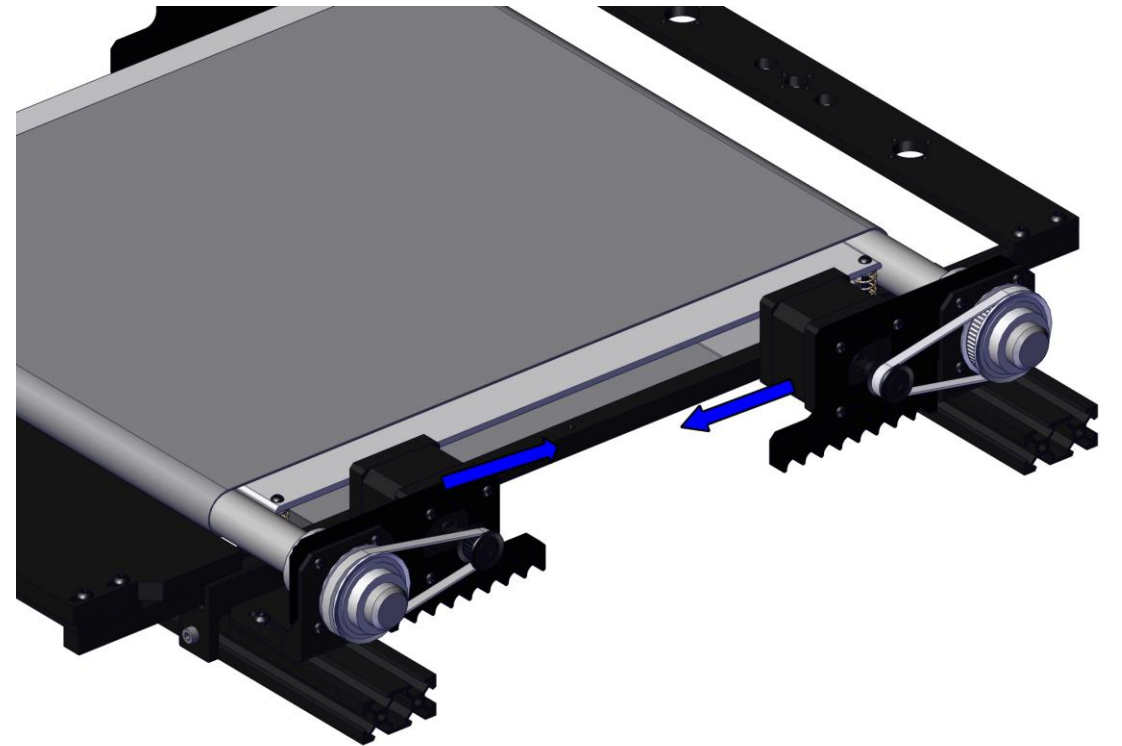

# Step 37

## Belt assembly and frame

Slide the assembly from step 36 into the assembly from step 22 and place the 40X20 extrusions onto the belt tightening sliders.

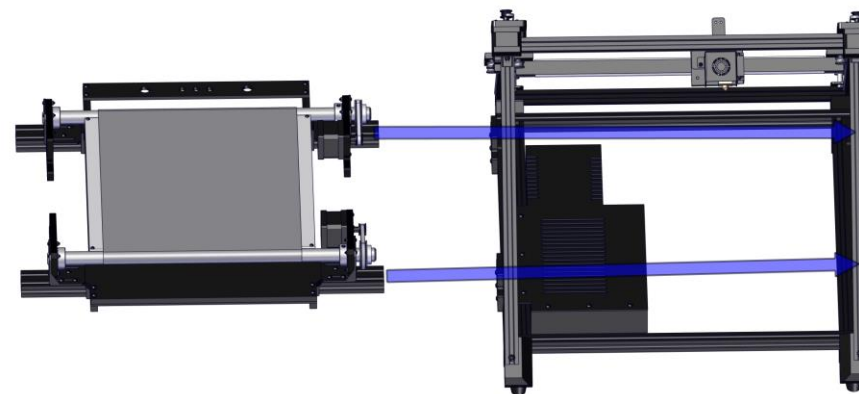

# Step 38

Belt assembly and mounting

Fasten the belt group and the belt tightening sliders with the 8 M5x25 screws.



# Step 39

Frame and corner bracket

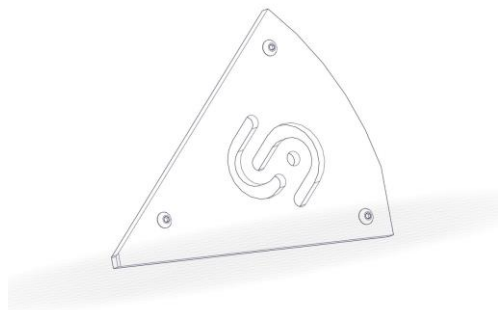

Side bracket

Mount the corner brackets with the logo on the front outer corners.

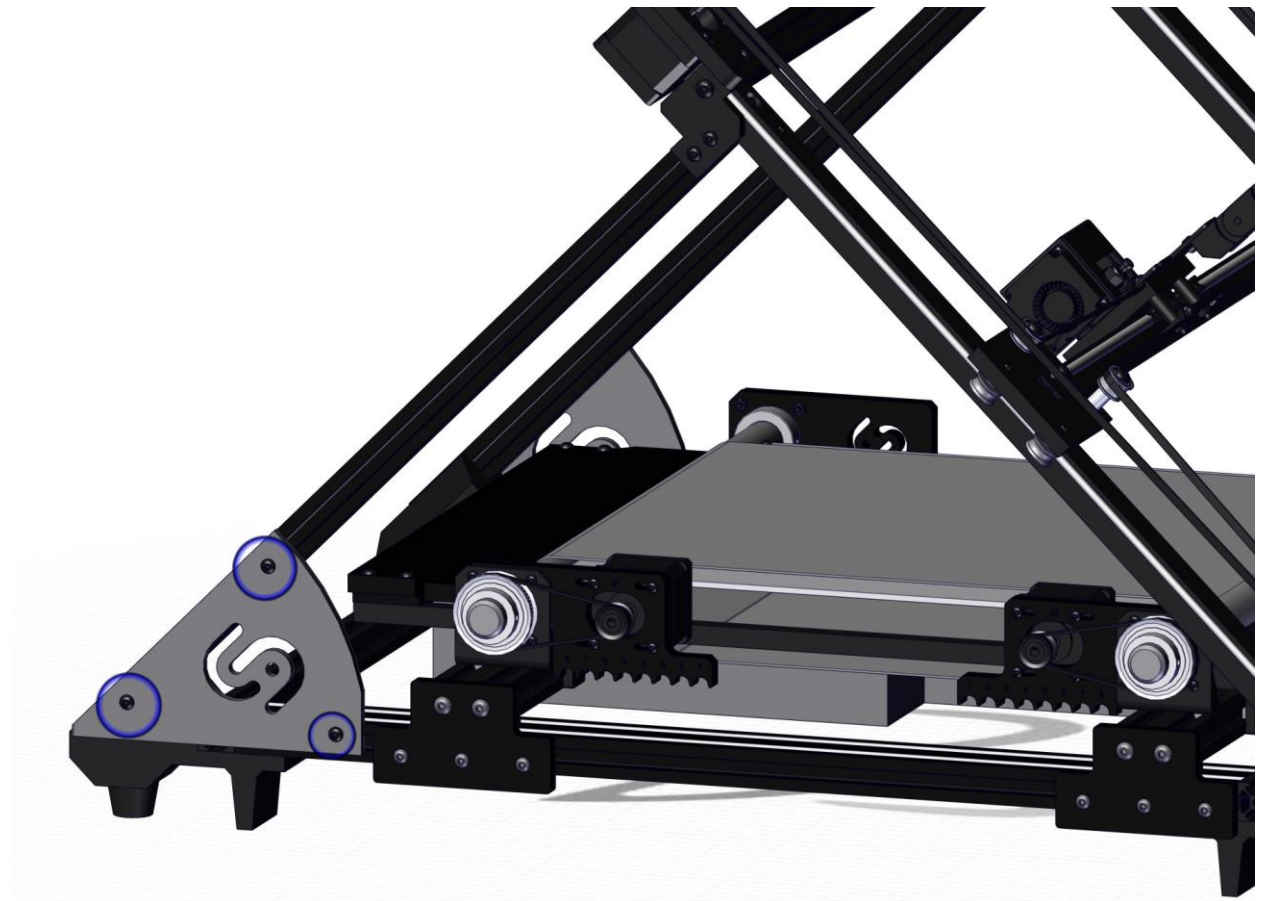

# Step 40

Belt and tightening

Pull the two back belt tightening sliders as far as possible to the back and tighten the M4 screws.

Pull the two front belt tightening sliders in the direction of the side plates with the iFactory3D logo and fasten the sliders as soon as they hit the side plates.

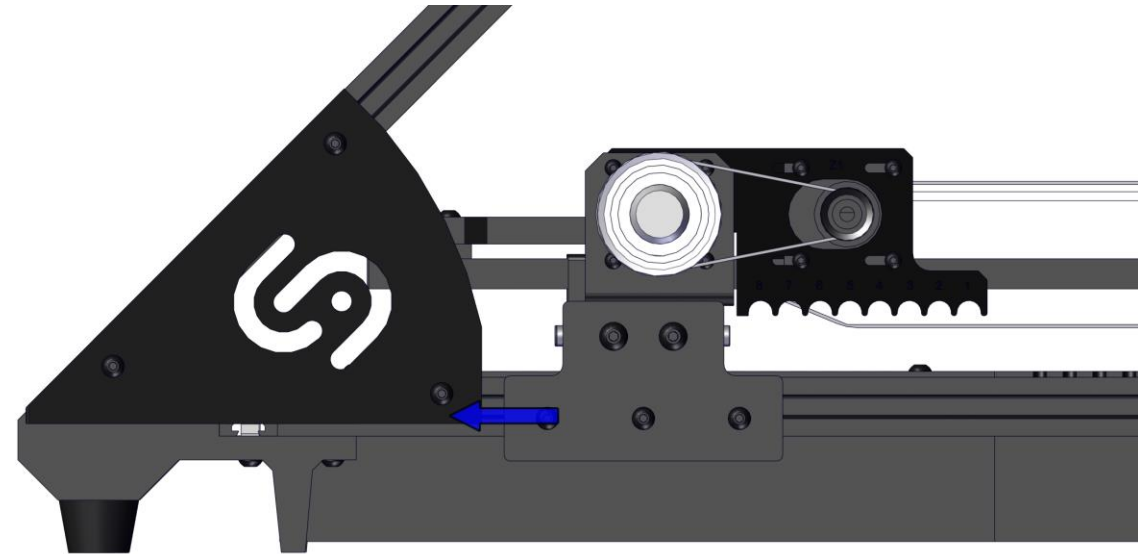

# Step 41

## Rods and tightening

8mm rod

Now place the two 8mm rods between the downside of the belt and the downside of the square bar and clip it into the fitting of the bearing brackets. The fittings are numbered, and the rods need to be at the same number to apply the tension evenly to the belt.

The higher the number of the fitting, the more tension is applied to the belt.



# Step 42

rod and collar

Place a 8mm collar to each end of the 8mm shaft and push them inwards.

When the collars hit the motor brackets, tighten the headless screws in the collars.

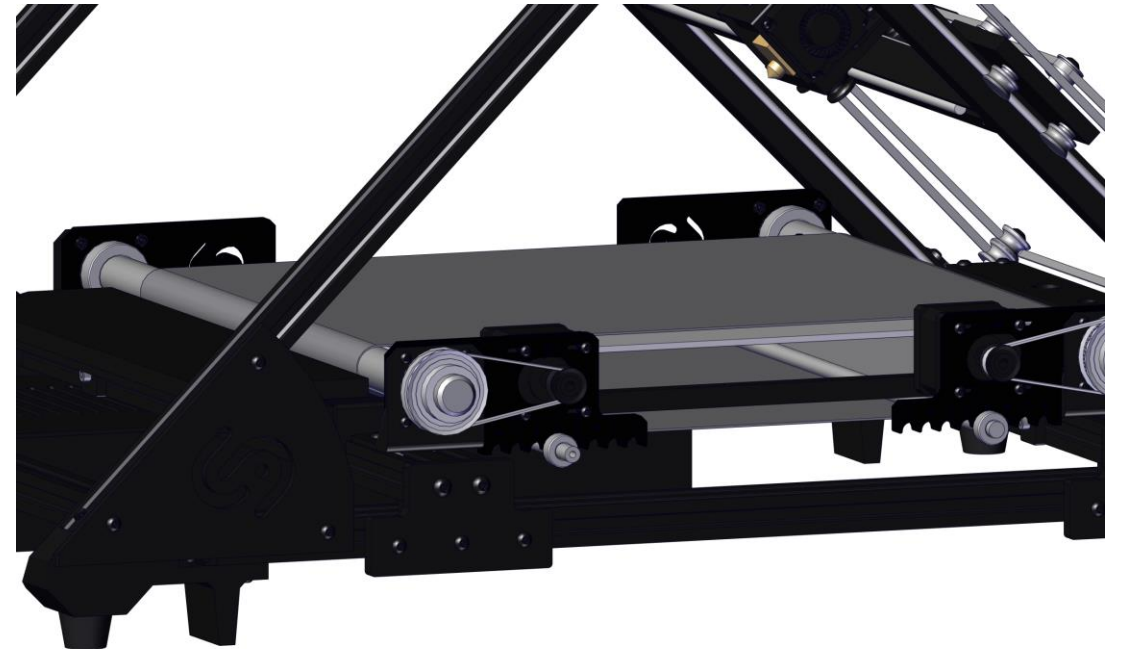

# Step 43

## Extruder and extrusion

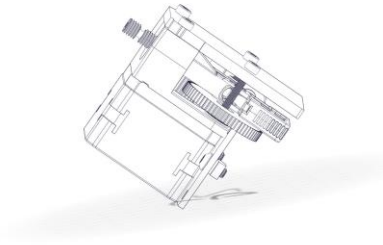

Extruder

Mount the extruder on the upper profile 10 cm away from the X-motor.

Move the printhead to the lower right corner of the belt (longest distance to the extruder). Then mount the Bowden cable. Then clip the Bowden cable clips over the hose coupling on the extruder and the hotend to secure the position of the Bowden cable.

There is a smaller bowden tube in the package that runs between the filament sensor and the extruder.





# Step 44

Filament detection and extrusion

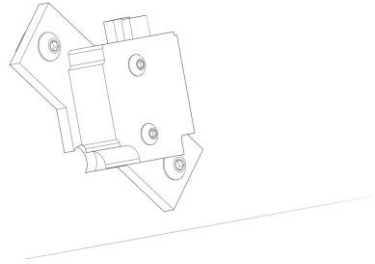

Filament detection

Mount the filament detection to the left side of the printer under the X stepper motor.

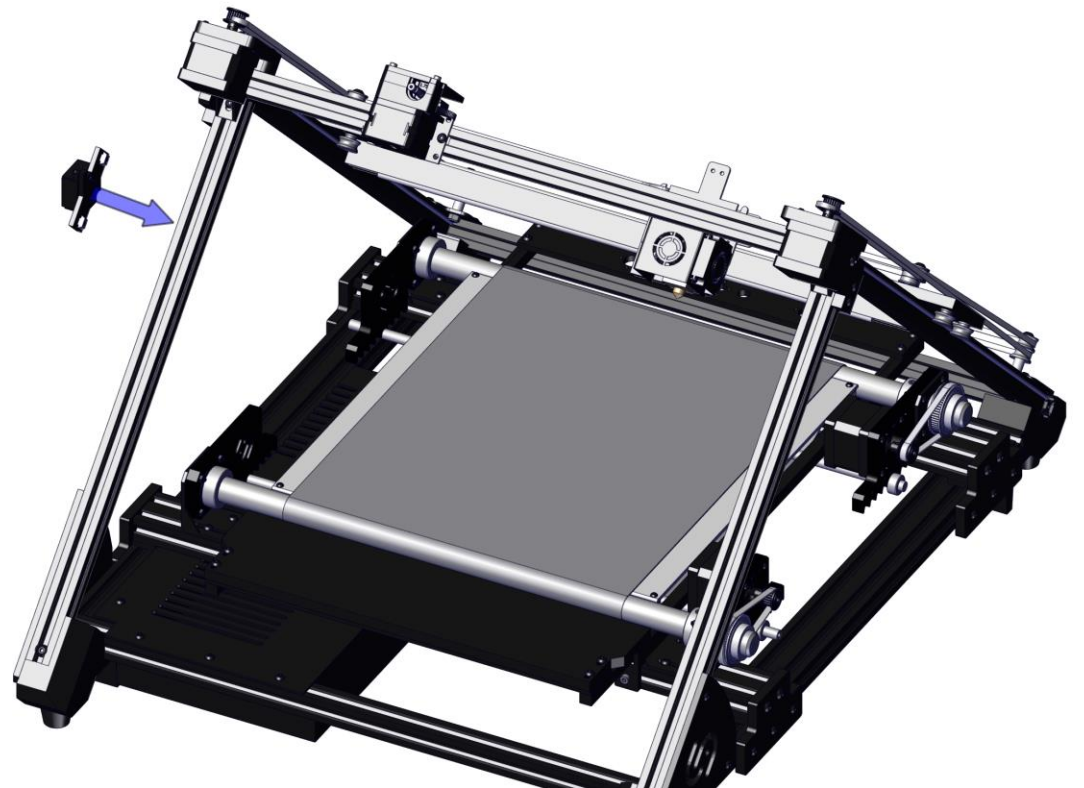

# Step 45

## Spool holder and extrusion

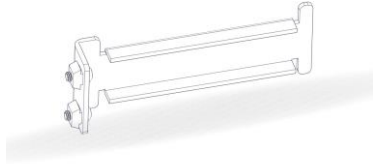

spoolholder

Place the spool holder on the left side between the filament end stop and the front feet.

Do not place the spool holder too close to the filament end stop, because this might cause the end stop to not work properly.

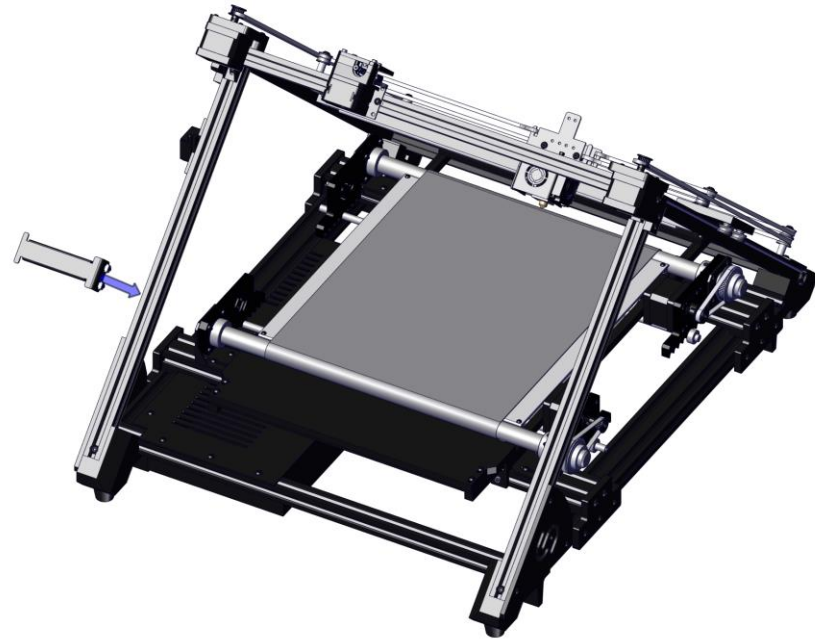

# Step 46

## Electronic board and extrusion

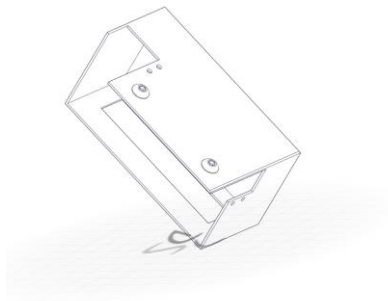

Electronic board

Lead the cables out of the upper hole of the electronic board (cut the zip ties from the X-Motor cable).

Place the electronic board directly under the filament endstop.

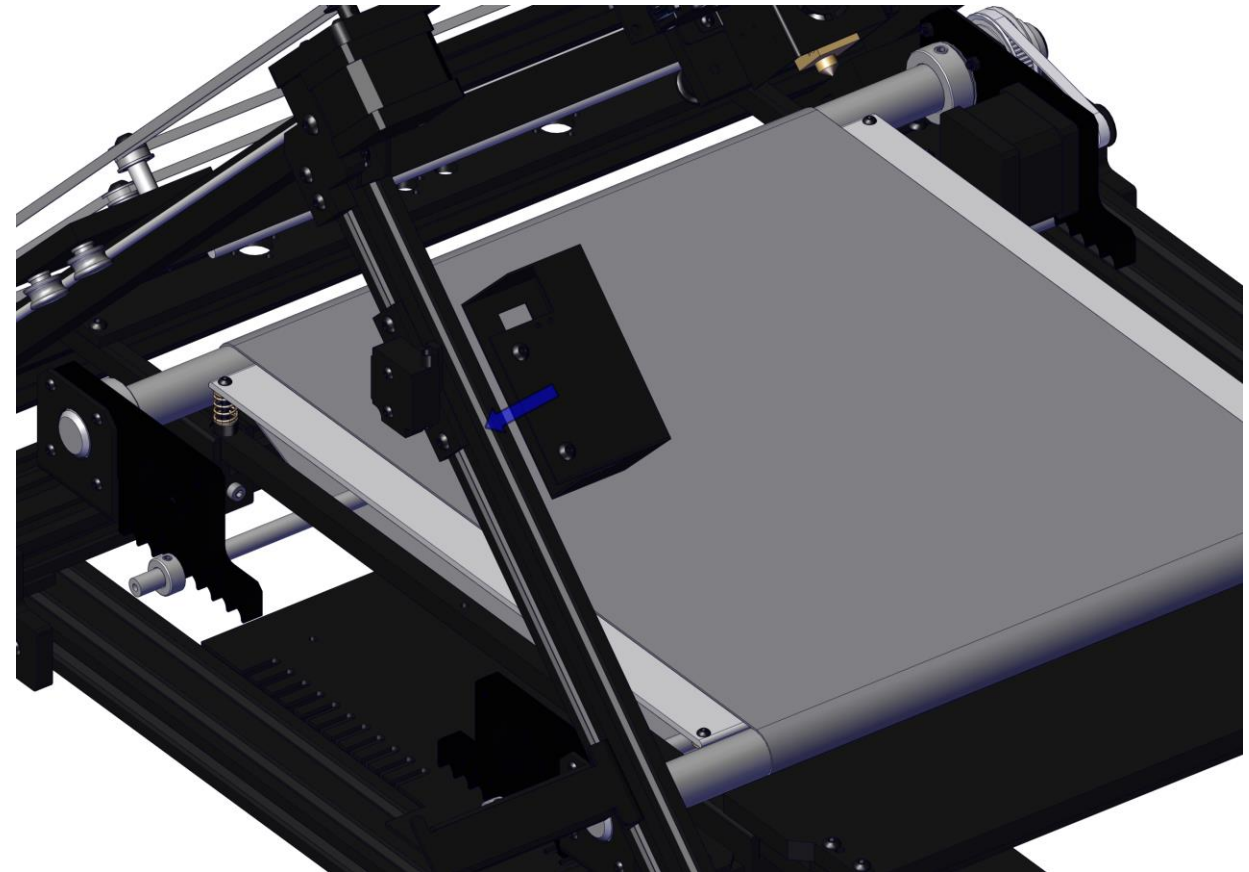

# Step 47

## Drag chain holder and extrusion



Drag chain holder

Mount the drag chain holder onto the right side of the extruder with the pre-assembled screws.

Mount the cable chain to the holder and the printhead.



# Step 48

Y endstop and guide rail

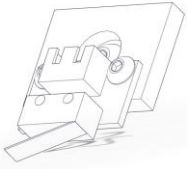

Y endstop

Mount the Y endstop under the X stepper motor as shown in the picture.

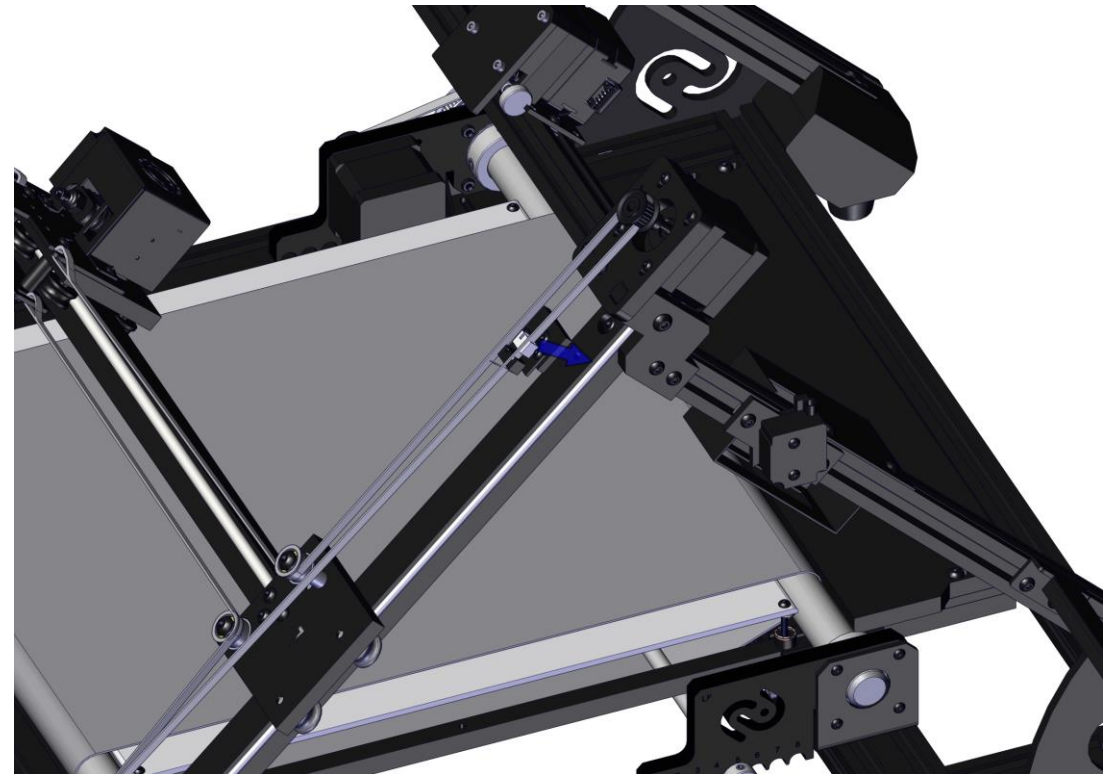

# Step 49

## Power supply holder and extrusion

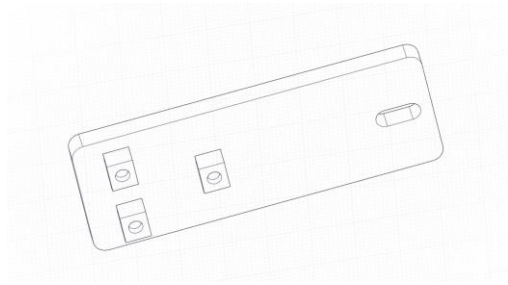

Power supply holder

Mount the power supply holder on the 40x20 aluminum extrusion and connect it with the power supply.

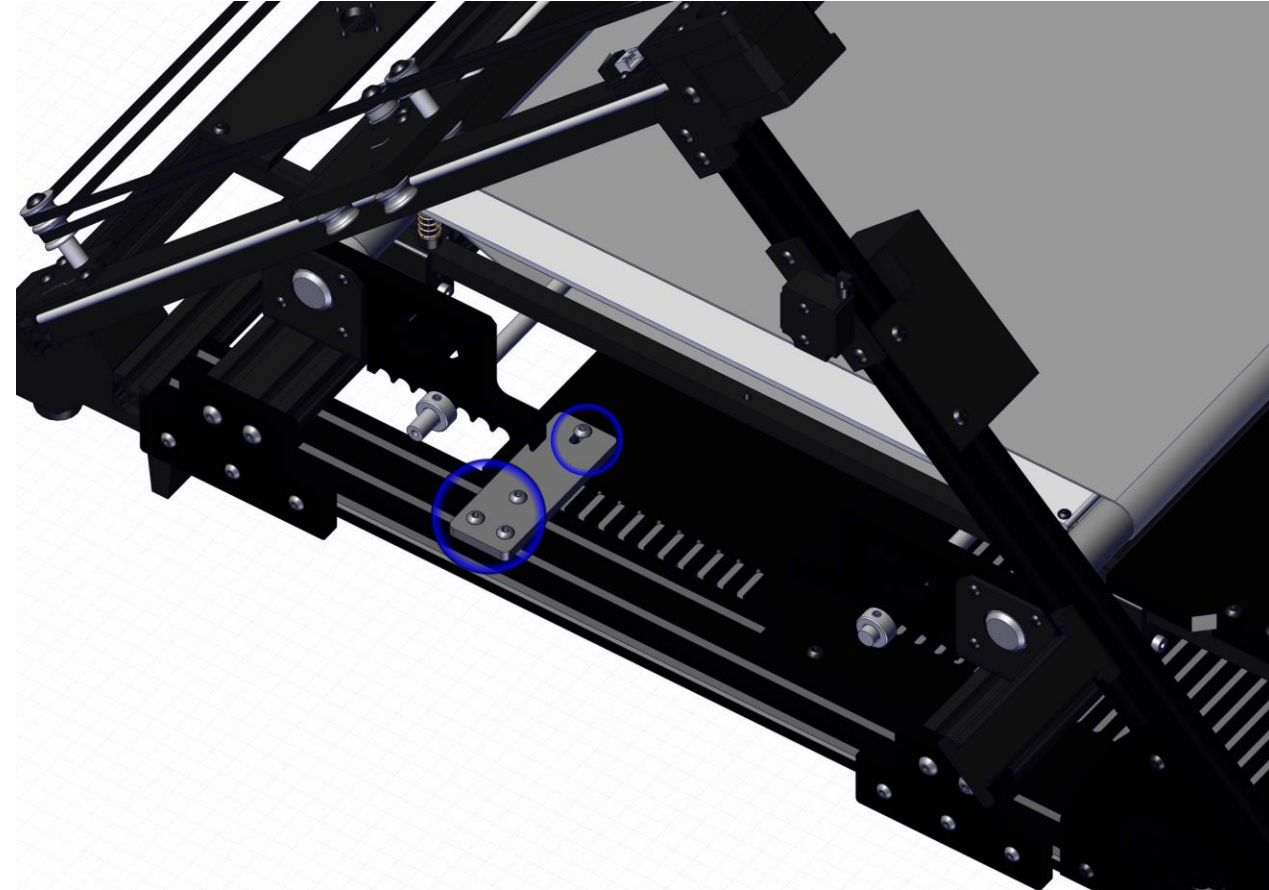

# Step 50

## Display and Extrusion



Display

Mount the display case on the front right corner of the printer (as shown in the picture) and connect it to the mainboard using the provided USB cable.



# Step 51

## Marlin Display

Mount the 2nd display (Marlin Display) directly under the 1st display. This display is used to enable printing from the SD card.

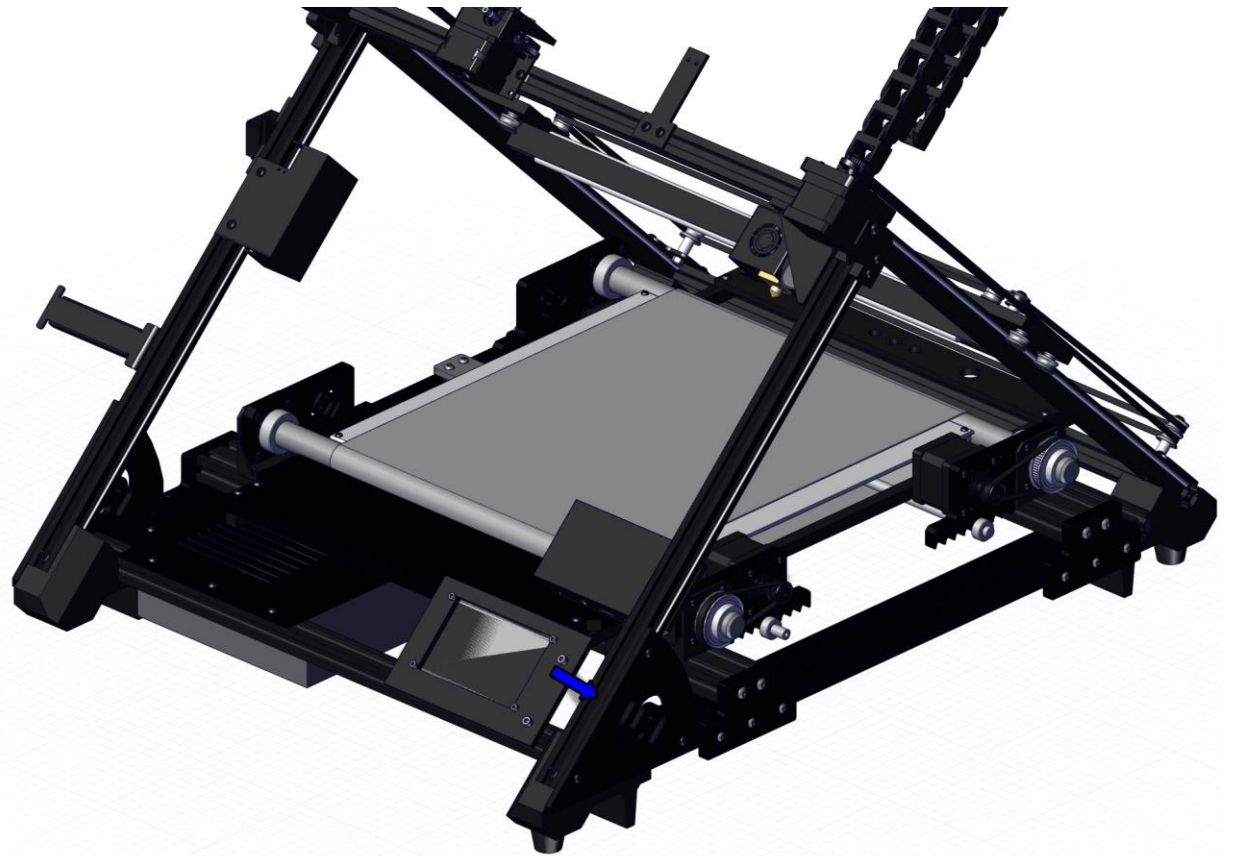



# Step 52

## Cam and Extrusions

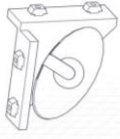

Cam

Mount the camera on the top right corner.

Note: If the camera does not work from the start, gently press the small brown plug inside the camera eye. Then restart the printer.

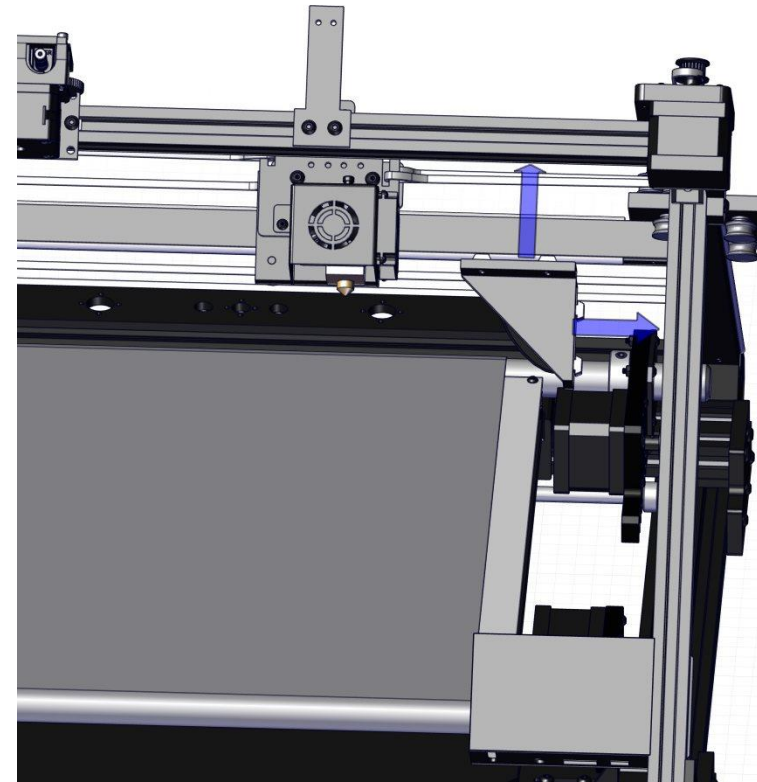

# Step 53

## Printing position and adjusting

In the end, the printing position needs to be checked. For that, push down the printhead until the nozzle touches the belt. The nozzle should print on the heated bed, but sometimes the nozzle is positioned between the back shaft and the heated bed. In that case, loosen the M4x20 screws in the scraper and push the whole bed group in the back direction until the nozzle is above the heated bed. Afterwards, the M4x20 screws need to be tightened again.

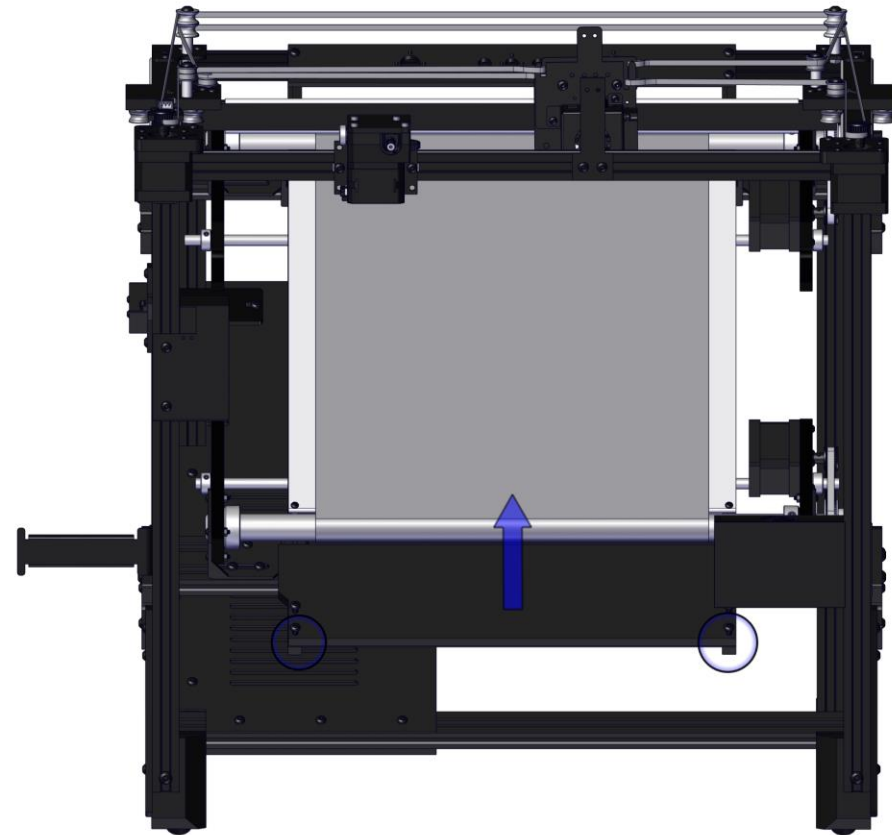

# Step 54

Securing the printing position

Secure the printing position with two M3 screws as shown in the picture.

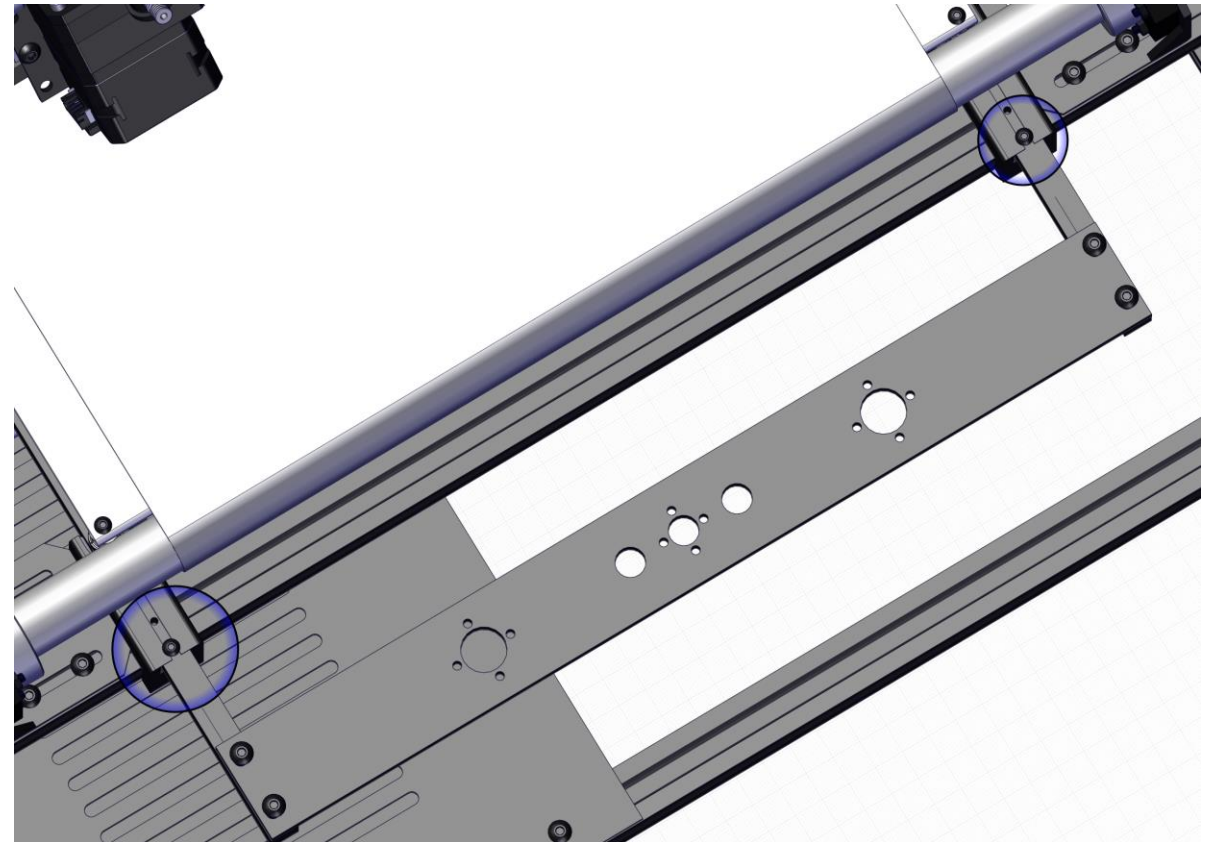

# Step 55

## Cabling

- Mount the cables following their labels to the stepper motors. One motor cable is not labeled. This is the cable for the Z1 motor (front Z motor).
- Plug the large ribbon cable from the mainboard box into the electronic board for cables.
- Mount the cables of the heated bed to the mainboard box.
- The Z and Y stepper motor cables come directly from the mainboard box and need to be connected as well.
- Connect the Y endstop directly to the mainboard box.